

FM 24-22

# Communications-Electronics Management System

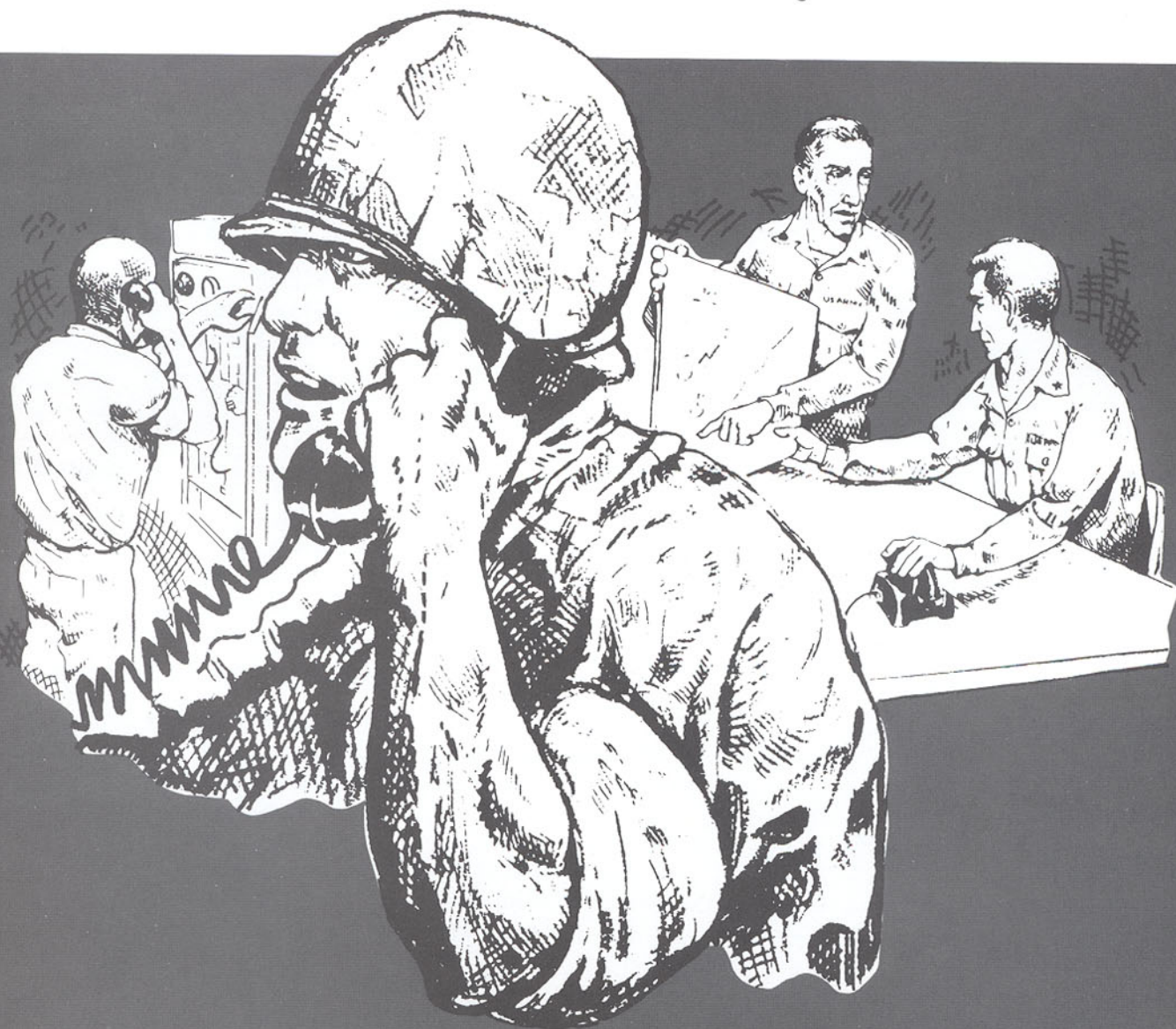

# **Contents**

---

<b>Chapter 1. C-EMS Development</b>	<b>Page</b>
Paragraph 1-1. Introduction .....	1-1
1-2. The Need for C-EMS .....	1-2
1-3. The Design of C-EMS .....	1-2
<b>Chapter 2. Management Objectives</b>	
Paragraph 2-1. Introduction .....	2-1
2-2. Management Policies .....	2-3
2-3. Standardization of Technical Parameters .....	2-3
2-4. Equipment Compatibility .....	2-4
2-5. Terminology .....	2-4
2-6. C-E Management .....	2-4
<b>Chapter 3. The C-E System</b>	
Paragraph 3-1. Introduction .....	3-1
3-2. Theater of Operations .....	3-2
3-3. Area Communications .....	3-3
3-4. Corps Communications System .....	3-5
3-5. Division Communications System .....	3-7
3-6. Brigade Communications System .....	3-8
<b>Chapter 4. Management Structure</b>	
Paragraph 4-1. Introduction .....	4-1
4-2. Theater and Theater Army C-E Management .....	4-2
4-3. Theater Communications Command (Army) (TCC(A)) .....	4-3
4-4. Corps Level C-E Management .....	4-4
4-5. Division Level C-E Management .....	4-6
<b>Chapter 5. C-E Planning</b>	
Paragraph 5-1. Introduction .....	5-1
5-2. Relationship Between C-E Planning and Engineering .....	5-2
5-3. Preparation of C-E Estimates, Plans, and Orders .....	5-3
5-4. Procedures .....	5-5
5-5. Maintenance of Records .....	5-5
5-6. Assessment and Allocation of Resources .....	5-8
5-7. Responsibilities for Assessment and Allocation .....	5-9
5-8. Validation of User Requirements .....	5-9
5-9. Preferential Services .....	5-10
5-10. Issuing Technical Directives .....	5-11
5-11. Introduction of New Equipment .....	5-13
5-12. Radio Frequency Management .....	5-14
5-13. International Frequency Control .....	5-14
5-14. Frequency Management Channels .....	5-15
5-15. Theater Level Frequency Management .....	5-15
5-16. Theater Army Frequency Management .....	5-15
5-17. Corps Level Frequency Management .....	5-17

5-18. Division Level Frequency Management .....	5-18
5-19. The Automated CEOI .....	5-18
5-20. Contingency Planning .....	5-19
5-21. Recording User Locations .....	5-20
5-22. Security .....	5-20
5-23. Messenger Service .....	5-21
5-24. Directory Service .....	5-22

## Chapter 6. C-E Systems Engineering

Paragraph 6-1. Introduction .....	6-1
 6-2. Network Layout .....	6-2
6-3. Traffic Engineering .....	6-4
6-4. Traffic Engineering Responsibilities .....	6-7
6-5. Telephone Traffic Engineering .....	6-7
6-6. Teletypewriter/Data Traffic Engineering .....	6-8
6-7. The Circuit Routing List/Bulletin .....	6-11
6-8. Traffic Diagrams .....	6-11
6-9. Traffic Route Bulletin .....	6-15
6-10. Line Route Map .....	6-15
6-11. Multichannel Systems and Radio Net Diagrams .....	6-17
6-12. System Performance Analysis .....	6-22
6-13. Electronic Counter-Countermeasures (ECCM) .....	6-24

## Chapter 7. Control Functions

Paragraph 7-1. Introduction .....	7-1
7-2. Communications System Control Element (CSCE) .....	7-1
7-3. Communications Nodal Control Element (CNCE) .....	7-2
7-4. C-E System Deactivation .....	7-7

## Appendix A. References

## Appendix B. Telephone Numbering System, Transmission System Designation and Circuit Identification

Paragraph B-1. Tactical Telephone Numbering Plan .....	B-1
B-2. System Designation and Circuit Identification .....	B-3
B-3. System Designators .....	B-3
B-4. Circuit Designators .....	B-6
B-5. Priorities for System and Circuit Restoral .....	B-9

## Appendix C. Special C-E Forms

Paragraph C-1. Introduction .....	C-1
C-2. Communications System Information Summary .....	C-2
C-3. C-E Trouble Record .....	C-9
C-4. Operational Resources Record .....	C-12
C-5. Traffic Status Record .....	C-15
C-6. Special Communications Authorization Request .....	C-18
C-7. Telecommunications Service Order .....	C-20
C-8. Communications System Document Change Order .....	C-24
C-9. Master Station Log .....	C-26
C-10. System and Circuit Status Record .....	C-28
C-11. System and Circuit Status Record, Card 2 .....	C-32
C-12. Circuit Routing List .....	C-34

# C-EMS Development



## 1-1. Introduction

For a long period during the evolution of warfare, communications were unsophisticated and nontechnical. The means of communications consisted chiefly of messengers, and manually and mechanically generated signals. The most important and effective means was the commander speaking directly to his subordinates. Centralized management of communications was unnecessary (as well as impossible) due to the limited speed and range of the communications system.

As communications methods were converted to electronic systems, certain elements of standardization were necessarily imposed, but the concept of decentralized control remained unchanged. Within broad limits, commanders were able to use their communications assets as they saw fit to enable them to control, in the best possible way, those forces under their command. Communications between units received low priority. This was reflected in the limited interface between units as each unit went about its own mission. When one unit had to talk to another, the pace of the battlefield allowed time for them to get together to iron out differences in communications procedures, and thus there was no real need for C-E standardization.





a. Doctrine for the allocation and employment of tactical C-E resources called for every commander to be provided with the resources he needed to communicate with his subordinate commanders one echelon below. That commander, in turn, had the assets to communicate one echelon lower. The communications network paralleled the command structure. Doctrinal responsibility then existed from higher to lower units and also from right to left on the battlefield. At every echelon, more than one means of communications were provided. Every signal unit was organized with the goal of providing a self-contained, dependable, flexible, secure, and rapid communications capability.

b. The structure developed for management of the C-E system was much the same at each echelon. Each commander had a subordinate signal unit to operate his communications system and a staff officer to advise him. Management functions were divided between the staff and the subordinate signal unit. To enable each commander to employ communications as he saw fit, decentralized control at each echelon was practiced.

## **1-2. The Need for C-EMS**

With the introduction of electronics to communications, the battlefield environment changed. The demands placed upon communications also dramatically changed. Time is a most important factor and distance becomes less and less significant. With increases in mobility and technology, units now move more quickly and shoot more accurately; thus, commanders must be able to exercise pinpoint control. New administrative and logistics systems require the transmission of large amounts of data to support the commander. Subscribers must now communicate throughout the width and depth of the battlefield. The intensifying requirements for dependability, flexibility, speed, security, and volume capacity increased as mobility on the battlefield caused interdependence among units. Interface between units and between their communications systems became a major concern.

To meet the demands of today's Army, highly sophisticated C-E equipment is required. To provide voice, teletypewriter, facsimile, or data communications across the battlefield, high capacity trunk systems, tactical automatic voice, and data transmission systems are being fielded. To maximize their capabilities and to meet the total communications requirement, all of these systems must be integrated at every level.

## **1-3. The Design of C-EMS**

For successful integration of these systems, technical and managerial standardization must be imposed. A commander no longer operates his own communications without concern for systems integration. To do so would degrade not only his portion but also the entire network. Decentralized control is, therefore, no longer an acceptable management practice. For efficient and effective management of the C-E system, centralized control coupled with decentralized implementation is now a necessity.

a. C-EMS is designed to provide centralized control with decentralized execution. The system is capable of monitoring the status of resources and other baseline data necessary for planning and engineering tactical systems. It exercises dynamic technical control over tactical communications systems and coordinates the interfaces with other systems.

b. C-EMS encompasses such functions as the determination of equipment status, disposition and allocation of communications resources, determination of precedence, levels of security access, and equipment

interface capabilities at access points. It also includes the primary technical control functions (monitoring, testing, routing, failure prediction, restoring, and reporting) which must be on a real-time or near real-time basis.

c. C-EMS uses the current inventory equipment but is designed with sufficient flexibility so as to be able to accommodate developmental items as they become available. It will ultimately include those facilities being developed under joint DOD programs which will provide the tactical commander a fully automated systems control capability. Based on future configurations of equipment, acronyms previously associated with management and control are replaced with DOD/DA approved terminology as developed under the joint tactical communications program (TRI-TAC).

d. C-EMS is designed to cope with the complex mix of secure and nonsecure analog/digital communications equipment. The system will use automatic assistance to facilitate performance analysis and the dissemination of planning, engineering, and control information.

# Management Objectives

## CHAIN OF COMMAND

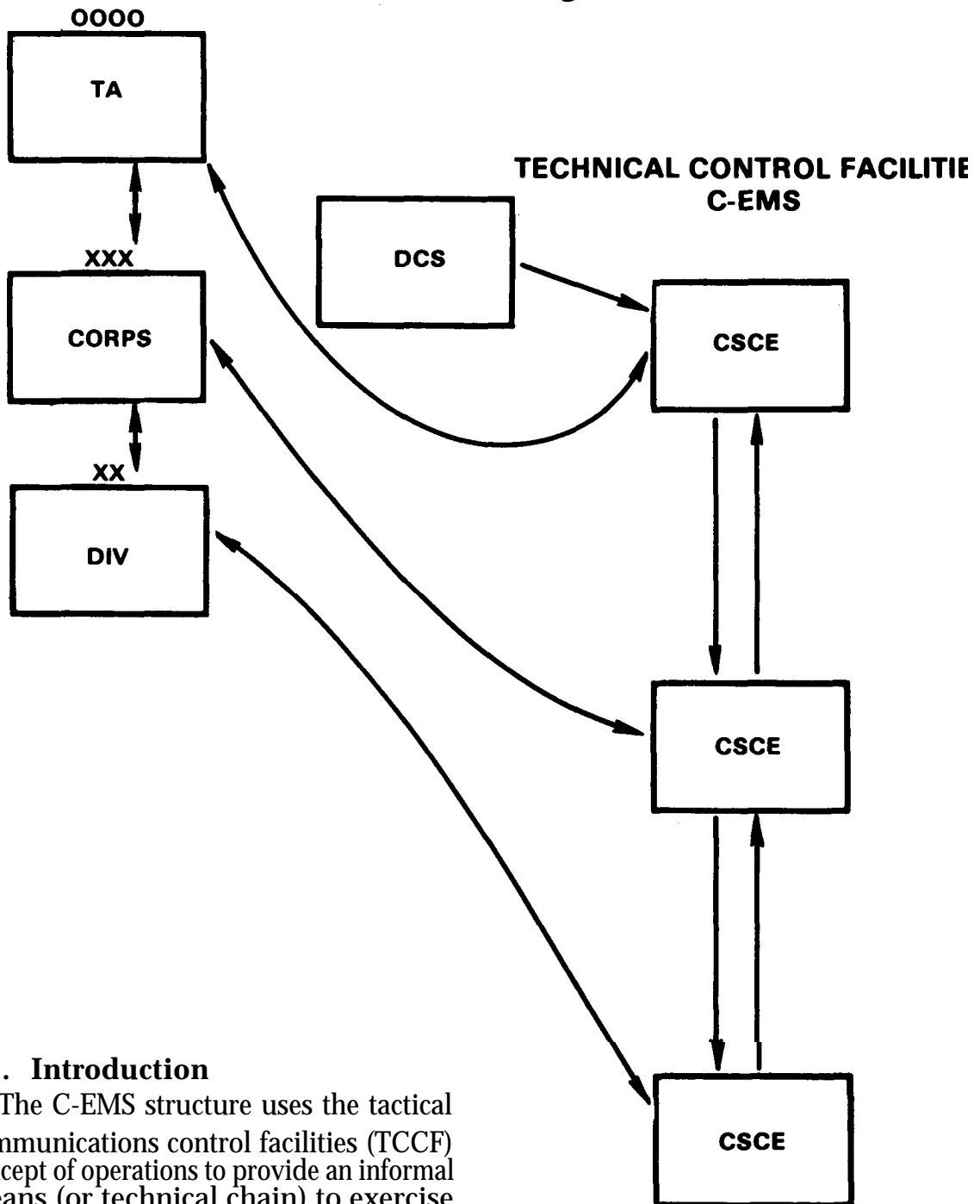

### 2-1. Introduction

The C-EMS structure uses the tactical communications control facilities (TCCF) concept of operations to provide an informal means (or technical chain) to exercise technical supervision over the operation of the communications systems. Elements of this C-E management structure are assigned to various echelons, with formal ties through the normal chain of command (fig 2-1).

**Figure 2-1. Chain of Command and Technical Control Facilities Parallel Structure**

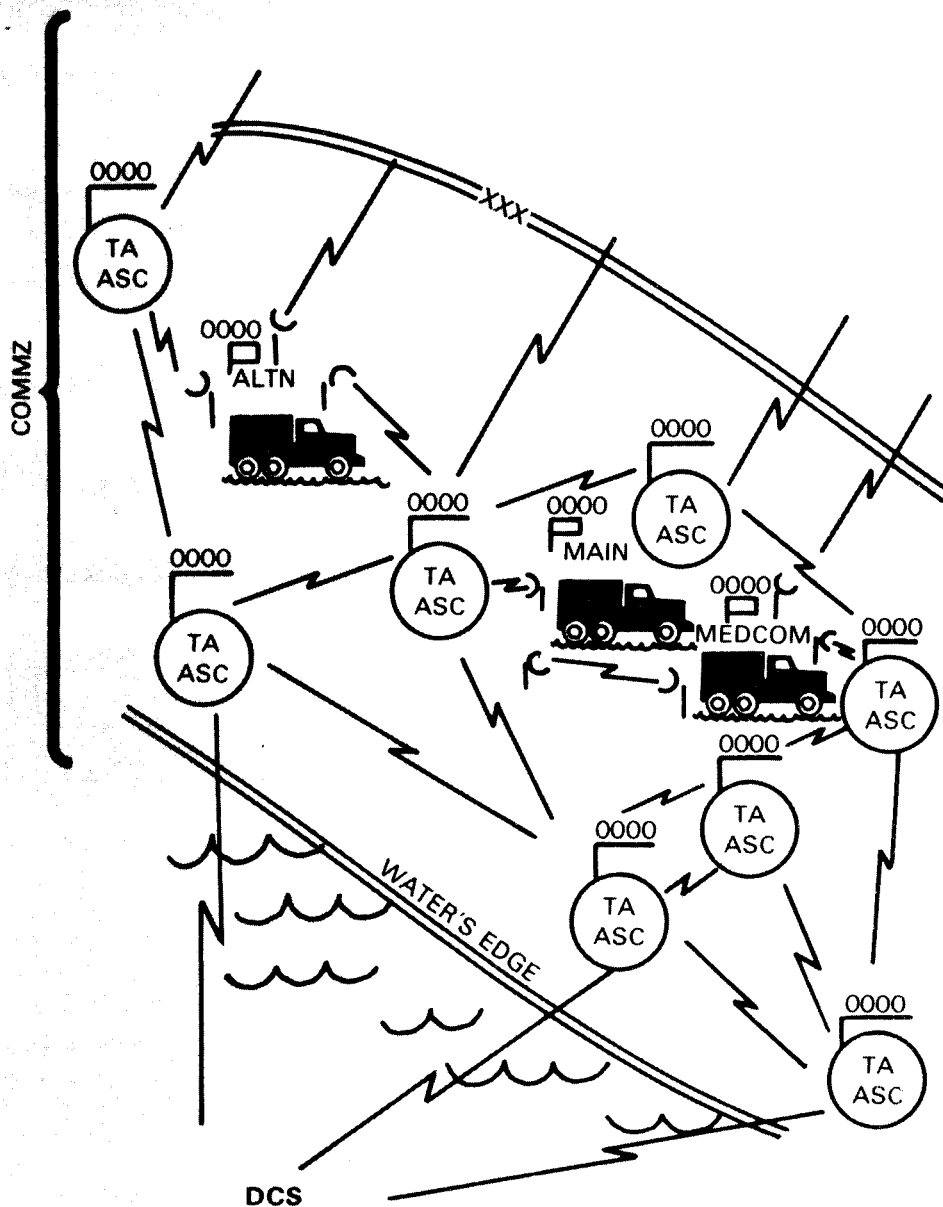

**Figure 2-2. Communications in the COMMZ**

a. C-EMS begins at the highest Army echelon within a theater of operations and extends down the chain to the operating elements located at each signal node, center, or site. The elements that actually exercise managerial and technical control at each echelon (i.e., theater army, corps, division) are described throughout this manual.

b. The doctrine of a command system superimposed on an area system provides the optimum communications system for a COMMZ (fig 2-2). The command system provides the theater army commander with the means to exercise command and control of combat operations; the area system serves the needs of the combat support and the combat service support elements. The two systems are again complementary because the signal centers at the major commands and major subordinate command headquarters have



access to both systems. Thus, when command headquarters move or when portions of either system become inoperative, high precedence traffic being passed over the affected system may be rerouted through operating portions of the other system. Interface points are provided to the DCS to provide worldwide access.

c. This manual establishes C-EMS procedures and techniques for the current and future C-E systems. The C-EMS provides management and control guidelines and C-E system standardization for commanders and staff elements who plan, engineer, and/or control these systems. The management and control doctrine established by C-EMS is based on the Department of Defense/Joint Tactical Communications Office (TRI-TAC) philosophy of joint services and the merger into a common C-E system. The joint service concept requires that certain conditions be made. These are—

- (1) Management policies, in both the planning and operating stages, must be harmonious, if not identical.
- (2) Technical parameters must be standardized.
- (3) Equipment must be compatible.
- (4) Terminology must be universal.

## **2-2 Management Policies**

Conditions will be established through an intensive standardization program that permeates the entire spectrum of C-E management. The conditions will be discussed in perspective to their impact on C-EMS throughout the manual.

a. C-EMS directs such functions as the determination of equipment status, disposition and allocations of communications resources, determination of precedence, levels of security access, and equipment interface. It also exercises direction of control functions (monitoring, testing, restoration, and reporting). The C-EMS organizational structure uses the TCCF concept to provide an operational chain that exercises technical supervision of communications system operation.

b. The individual parts of the control chain are assigned at the various echelons but operate the C-E systems under a “master plan” that specifies procedures and standards. The normal chain of command provides implementing supervision, insures adherence to directives, and identifies communications requirements to upgrade or improve support for combat operations.

c. The objective of immediate response to user needs dictates total understanding between C-E elements. C-EMS is dedicated to developing universal standards and procedures that achieve this. Planning, engineering, and installation operation will be understandable at all levels and by all members of the C-E community. C-E doctrine is a composite of DOD policy, Defense Communications Agency (DCA) technological direction, the concepts of TRI-TAC, and operational mission requirements.

## **2-3 Standardization of Technical Parameters**

DCA has systematically researched the problems encountered in the area of technical communications. This research has resulted in a usable data bank of technical communications standards (parameters). These standards (as set forth by DOD) apply to all services. Stringent application of these parameters to all circuitry will enhance interface capability and insure quality service to the subscriber.

Application of the exacting (and sometimes complex) parameters demands well-trained operators and supervisors. A comprehensive training

program is an absolute necessity to enable technical control, operator, and maintenance personnel to employ equipment properly.

## **2-4 Equipment Compatibility**

The TRI-TAC development program is directing the use of like equipment throughout DOD. The separate services are tasked for designing, testing, and procuring the new items (for instance, the Army is responsible for the tactical automatic switching (TAS) system; the Air Force is developing the TCCF). When the new family of equipment is fielded, inherent compatibility will be achieved. In the interim, use of current inventory equipment demands constant attention to interface problems.

## **2-5 Terminology**

To understand the C-EMS management structure, a common terminology is being introduced into the Army's C-E management system. The terminology used in this manual has been developed for use by all DOD services under the Joint Tactical Communications System Program (TRI-TAC). It is consistent with current developments for the Army's tactical C-E systems and developmental equipment that will be introduced into the signal community through the 1980's. It is approved by the Joint Chiefs of Staff for use with the TCCF.

Terminology must be universal. As new systems and techniques evolve, new descriptive terms will be used to describe both equipment and functions. New developments cannot be described in old terms with precision; so new terms have evolved for use throughout DOD. Generally, technical terms have been promulgated by DCA and are published in DCAC 310-70-1, Volume IV.

## **2-6 C-E Management**

Under the C-E management system, the management structure is divided into the four elements listed below and described in figure 2-3.

Element	Function
CSPE	Planning/Engineering
CSCE	Overall Control
CNCE	Local/Nodal Control
CESE	Operating Facility

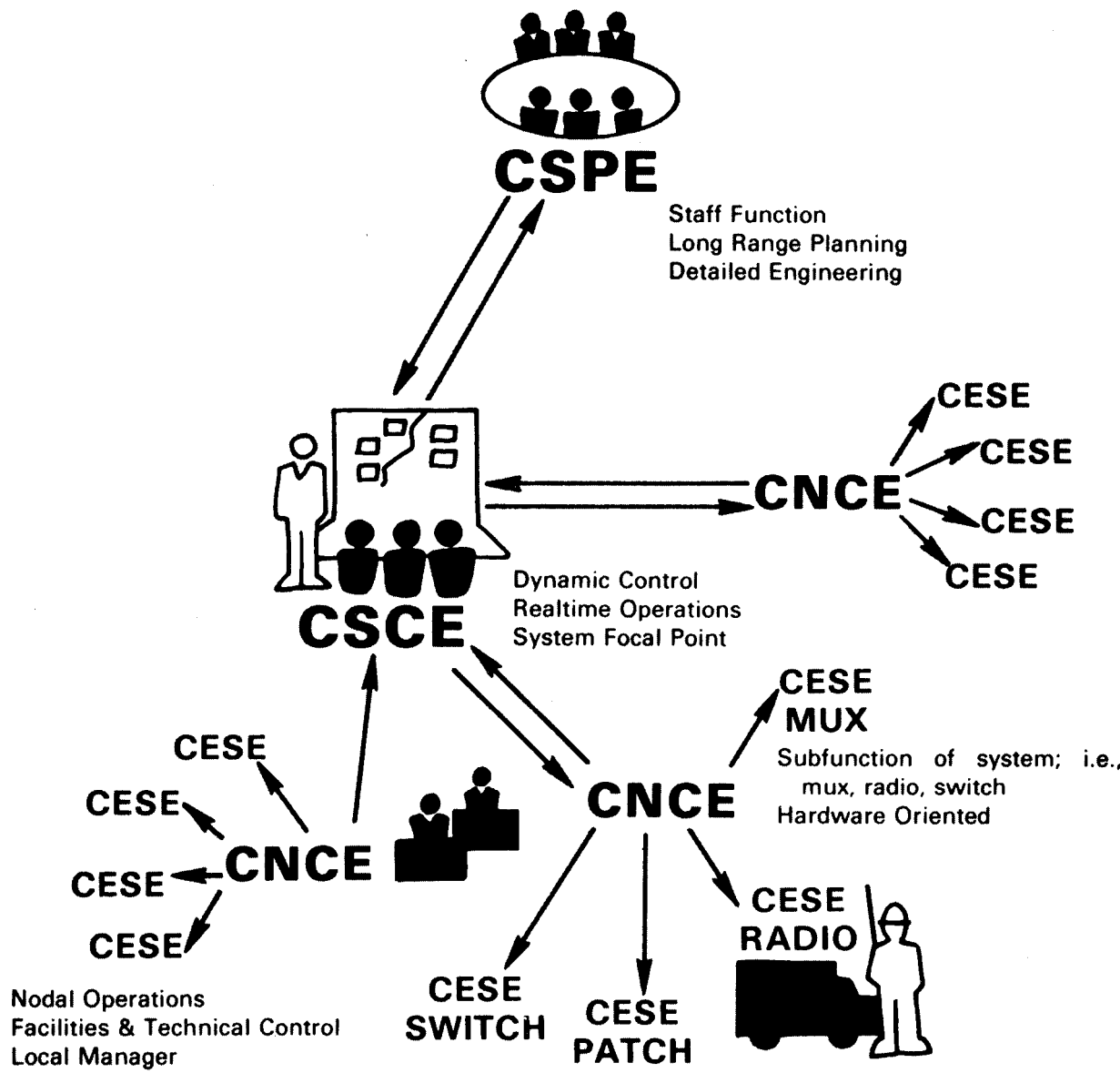

**Note:** C-E Management is divided into four sub groups

- CSPE            Planning/Engineering
- CSCE           Overall Control
- CNCE           Local/Nodal Control
- CESE           Operating Facility

**Figure 2-3. C-E Management**

# The C-E System

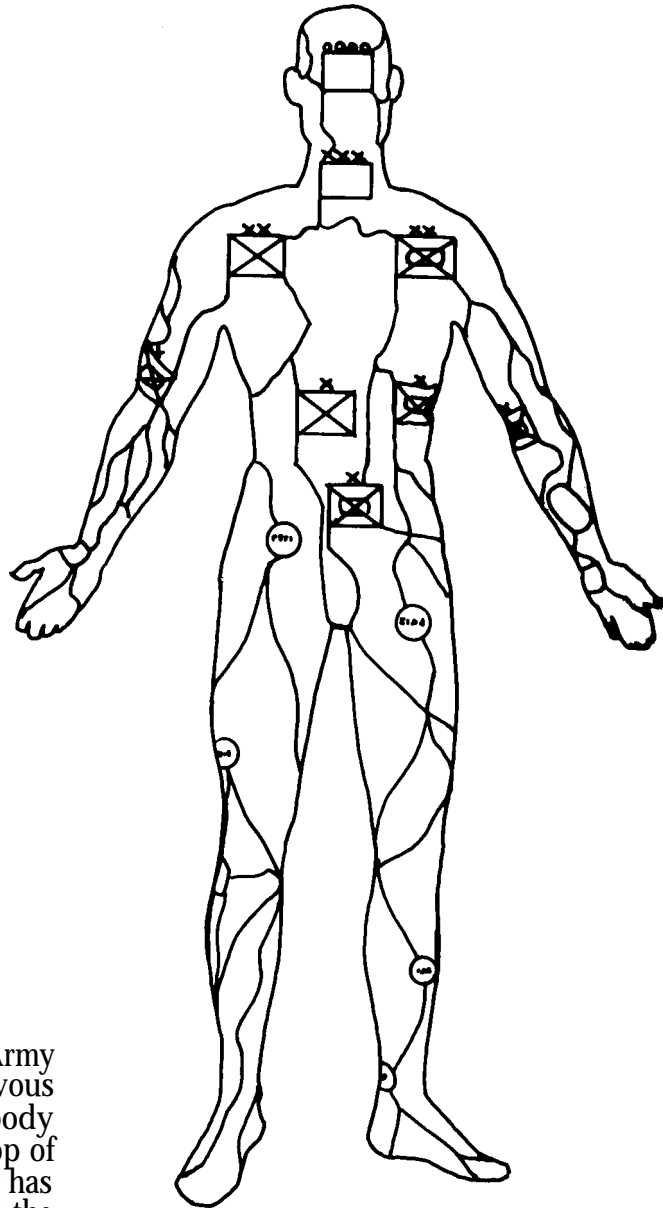

## 3-1. Introduction

The communications system of the Army in the field may be compared to the nervous system of the human body. Like the body which has nerves extending from the top of the head to the tip of the toes, the Army has communications circuits extending from the water's edge to the forward edge of the battle area (FEBA). In order for the Army to be responsive to its mission, the communications system must be reliable and provide rapid and secure exchange of information throughout the chain of command.

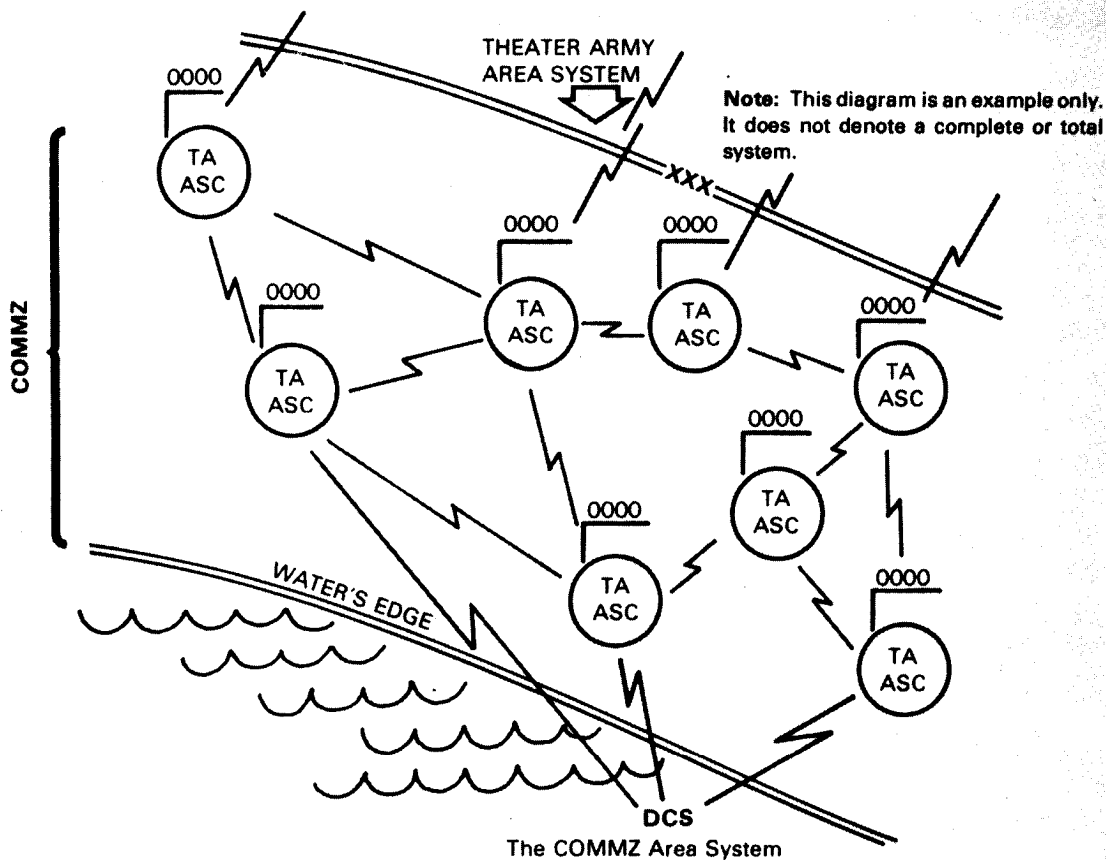

**Figure 3-2.** The COMMZ Area System

### 3-2. Theater of Operations

The communications system is widely dispersed over the entire theater of operations. The theater of operations is divided into the *combat zone* and the *communications zone* (COMMZ) (when adequate terrain is available).

a. The *combat zone* is that part of the theater of operations that is required for combat operations. The combat zone includes the ground, air, and sea areas where the commander directly influences the progress or outcome of operations by maneuvering his ground-gaining elements through delivery of firepower using fire support systems under his control or command. The size of the combat zone depends on the area of interest, mission, organization, and equipment of the force involved and the physical environment of the country. For tactical control, the combat zone may be divided into corps, division, and separate brigade areas. The commander of the unified command designates the rear boundary of the combat zone; the boundary may change as required by displacement of the combat forces.

b. The COMMZ is that part of a theater of operations behind the combat zone. It contains the communications facilities, logistics support elements, and other agencies required for the immediate combat service support of the field forces. The COMMZ includes sufficient area for the operation of supply, evacuation, transportation, and combat service support installations and for their defense. The COMMZ also includes any area necessary for the operation or support of Navy and Air Force elements based outside the combat zone. The rear boundary of the COMMZ is usually the rear boundary of the theater.

c. The organization of a theater of operations varies with the type of theater, the types of forces in the theater, and the nature of the operations planned. FM 100-10 provides a more complete discussion of the territorial communications zone.

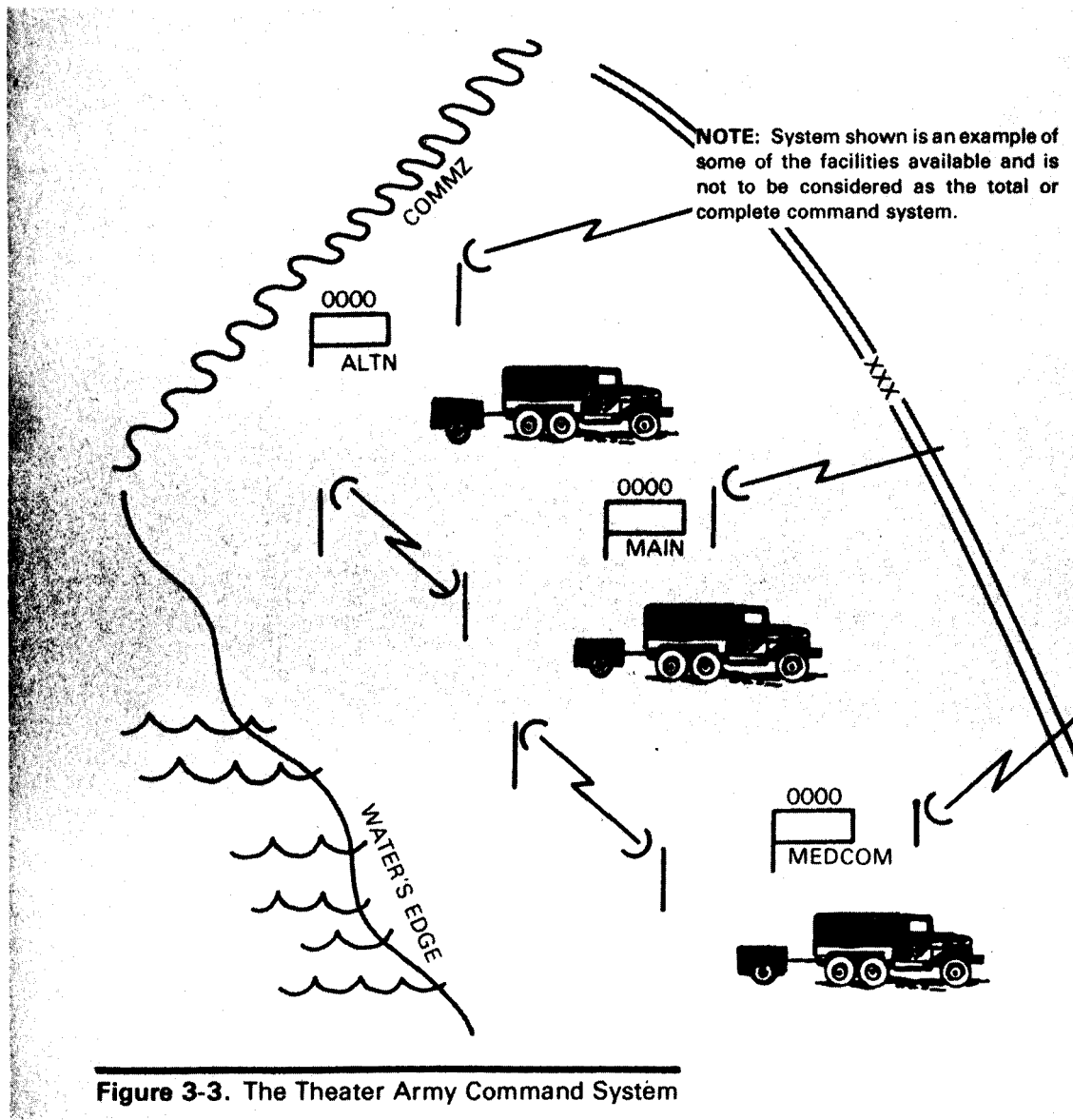
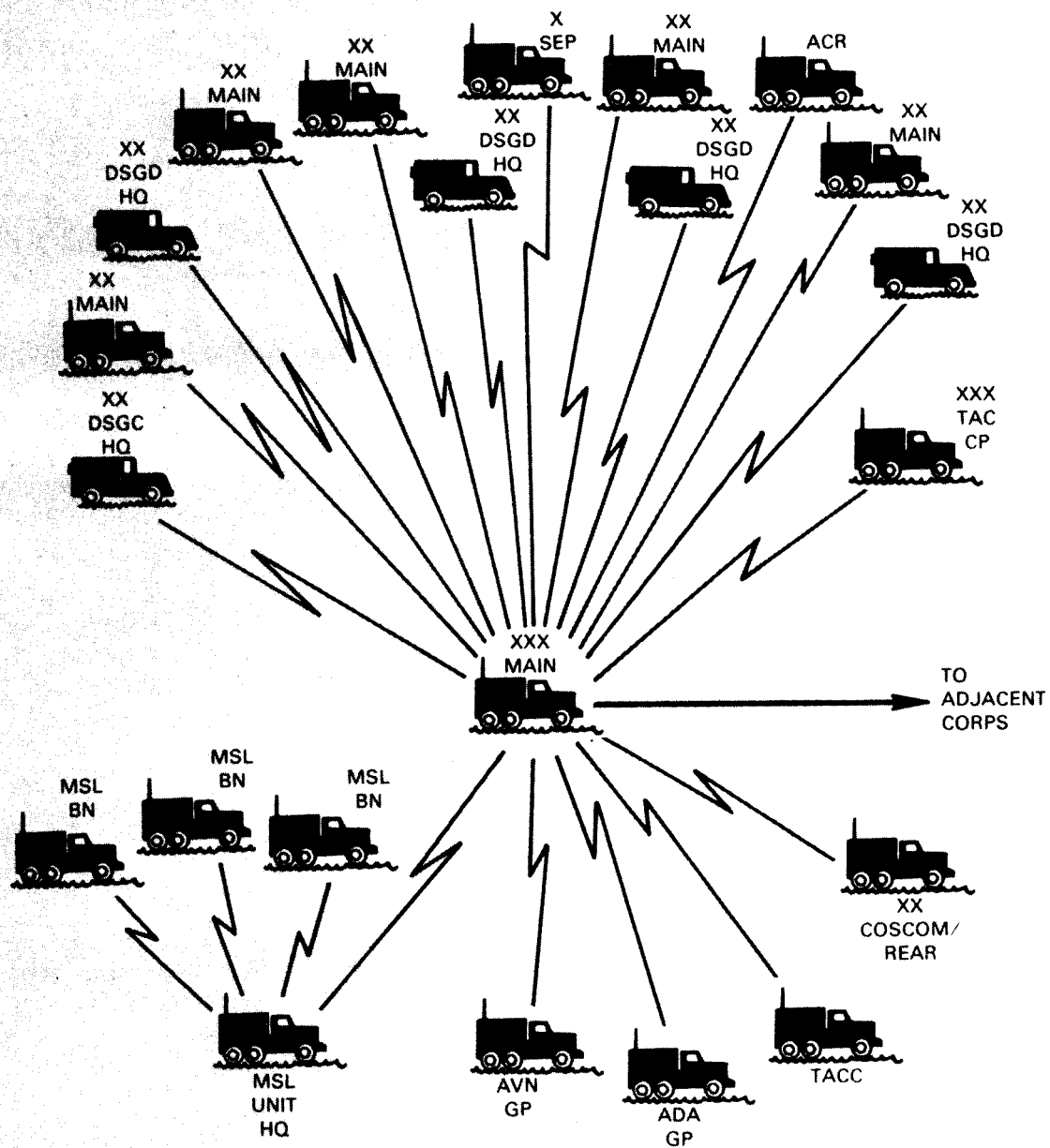

Figure 3-3. The Theater Army Command System

### 3-3. Area Communications

a. In the COMMZ, units of the theater communications command (army) (TCC(A)) install, operate, and maintain an area communications system. This area communications system consists of area signal centers (nodes) so situated throughout the theater army that a major subordinate headquarters located anywhere in the corps rear area or the theater army service area has ready access to the signal communications facilities of one of the nodes. These area signal centers are interconnected by multichannel communications facilities in a manner that permits routing from one area signal center to another through several paths. The requirement of the mission and the location, and size of units determine the number of area signal centers (nodes) established in the COMMZ.



**NOTE:** System shown is an example of some of the facilities and is not to be considered as the total or complete system.

**Figure 3-4. Corps Command System**

b. Also installed in the COMMZ is a command communications system. This system is superimposed on the area system to form an integrated network. Units of the TCC(A) install, operate, and maintain the theater army command communications system. The command system has multichannel voice communications, radio teletypewriter, and messenger service facilities. These facilities interconnect the theater army main and alternate signal centers and extend from these signal centers direct to



headquarters of major subordinate commands, such as the corps. Theater army signal units normally furnish the teams and equipment that are required to terminate the theater army command communications system at the subordinate headquarters.

c. There is only a limited requirement for single channel radio net facilities within the COMMZ, but a single channel net is provided as a backup to the multichannel links for special communications. Detailed information on theater army communications is contained in FM 11-23.

### 3-4. Corps Communications System

a. The corps communications system operates in the combat zone and provides communications for corps units. It is an integrated system employing multichannel communications facilities to provide service on both a command and area basis plus single channel command radio. Direct links are provided from the corps main to attached divisions and selected subordinate units within the corps area. The area communications system is interconnected with the command system and consists of no more than 16 area signal centers (nodes) situated to provide ready corps-wide access. The corps system also interconnects theater army, adjacent corps, and divisions.

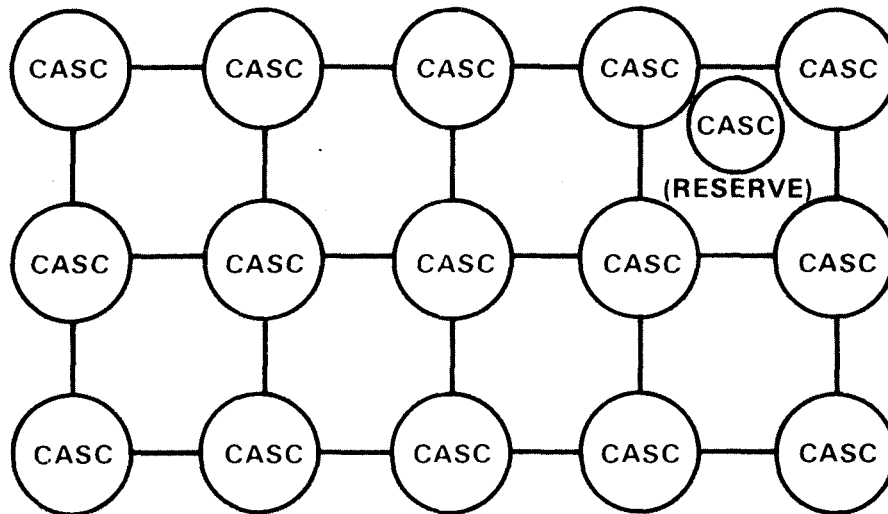

NOTE: System shown is an example of some of the facilities and is not to be considered as the total or complete system.

**Figure 3-5. Corps Area Communications System**

b. The corps area system may be employed as a grid, tandem, or combination grid and tandem network utilizing no more than 16 corps area signal centers (CASC). Usual employment is 15 CASC with one held in reserve for replacement/augmentation. Defense Communications System (DCS) entry into the system is based upon technical capability and command requirements.

c. Each CASC furnishes multichannel radio and wire facilities and local field wire and cable circuits to units in the vicinity requiring the service. Each area signal center also—

- (1) Furnishes telephone, telecommunications center, teletypewriter, data, cryptographic, and limited messenger services for units and installations in the area.
- (2) Provides patching and switching of telephone, teletypewriter, and data circuits.
- (3) Provides radio-wire integration (RWI) and retransmission services.
- (4) Provides interface with the DCS at selected sites (nodes).

d. The corps command communications system normally consists of direct links between corps main and attached or assigned major subordinate commands. Links are also provided to the corps tactical command post (TAC CP), corps rear/corps support command (COSCOM), and adjacent corps. For additional information on communications, consult FM 11-50, FM 11-92, and FM 24-1.

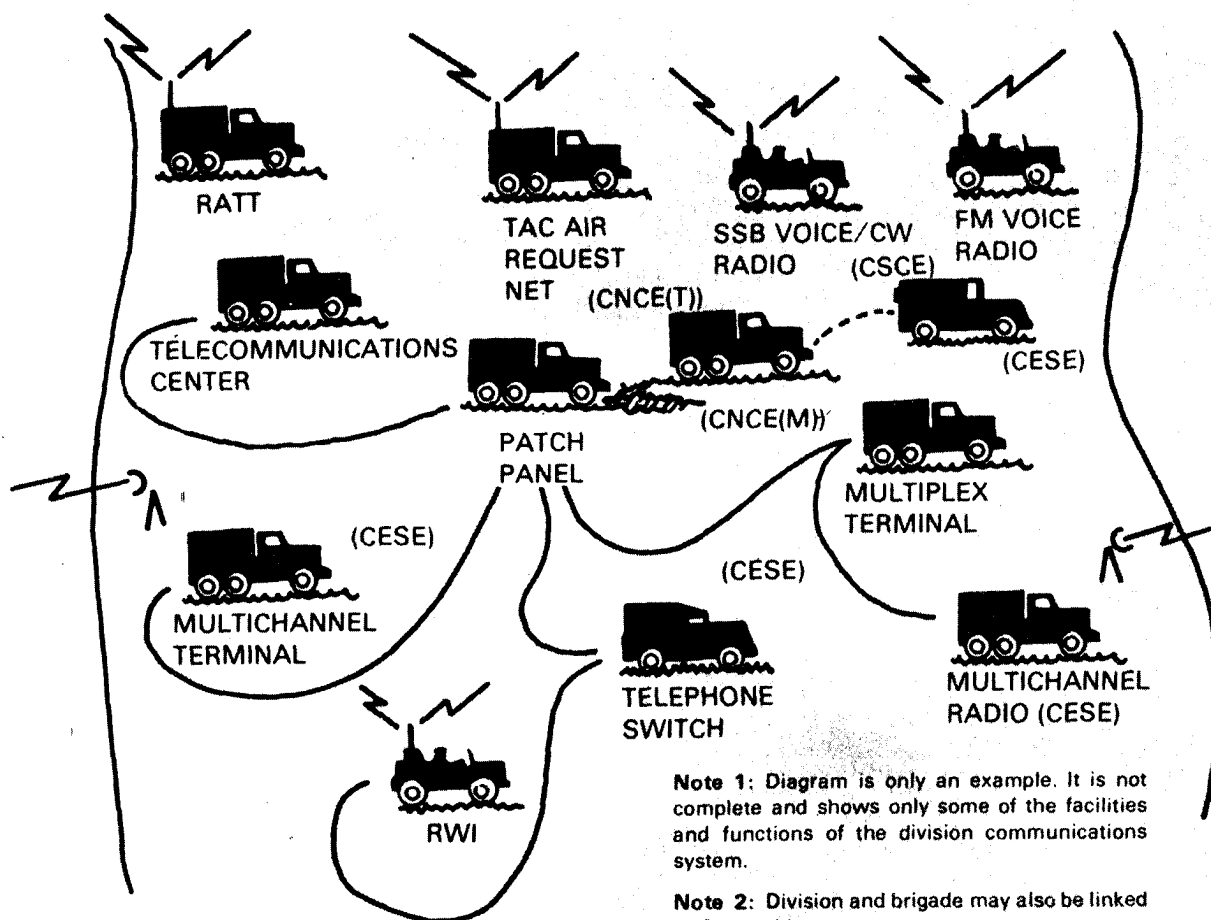

Figure 3-6. Division Signal Communications System

### 3-5. Division Communications System

The division uses an area communications system, a command communications system, RATT nets, and FM single channel radio nets to provide the commander with the necessary communications to effectively command and control his troops.

- a. The area system provides communications for administrative, logistical, and maintenance support. It also supplements the command system and provides access to the multichannel system for any support elements located in the vicinity of an area node.
- b. The command system provides the means necessary for division tactical operations and insures the priority of command/control communications. (See FM 11-50 for additional information.)
- c. RATT nets are established between echelons of the division to supplement and as backup to the command and area multichannel systems.
- d. Single channel FM voice nets are established between echelons of the division to provide the commander with a mobile, flexible means of command/control during the heat of battle when time is of the essence.
- e. With the use of RWI stations, the commander has access to the area and command multichannel systems even though he may be in a remote area or an aircraft with only FM radio for communications. (See TC 24-3.)

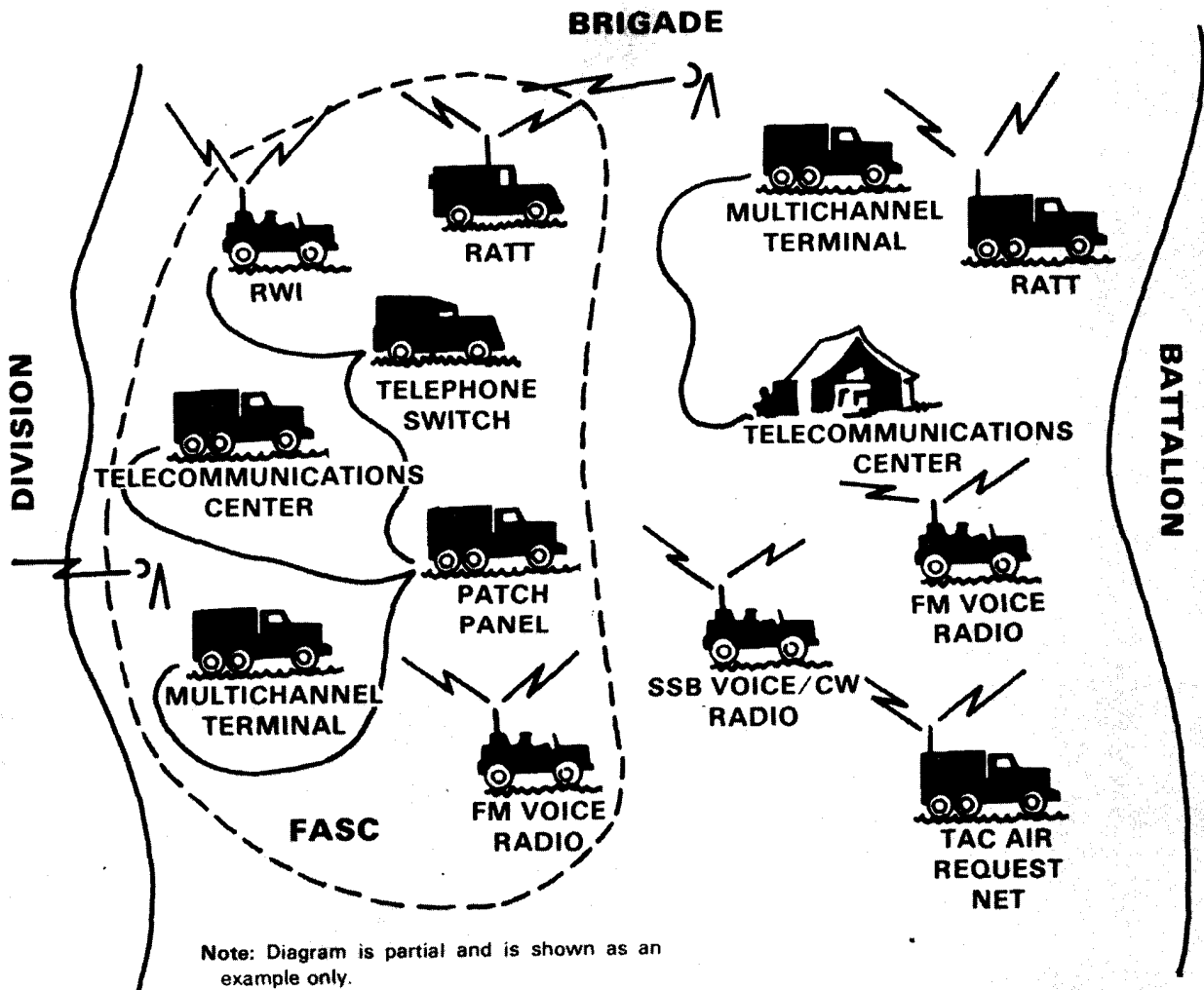
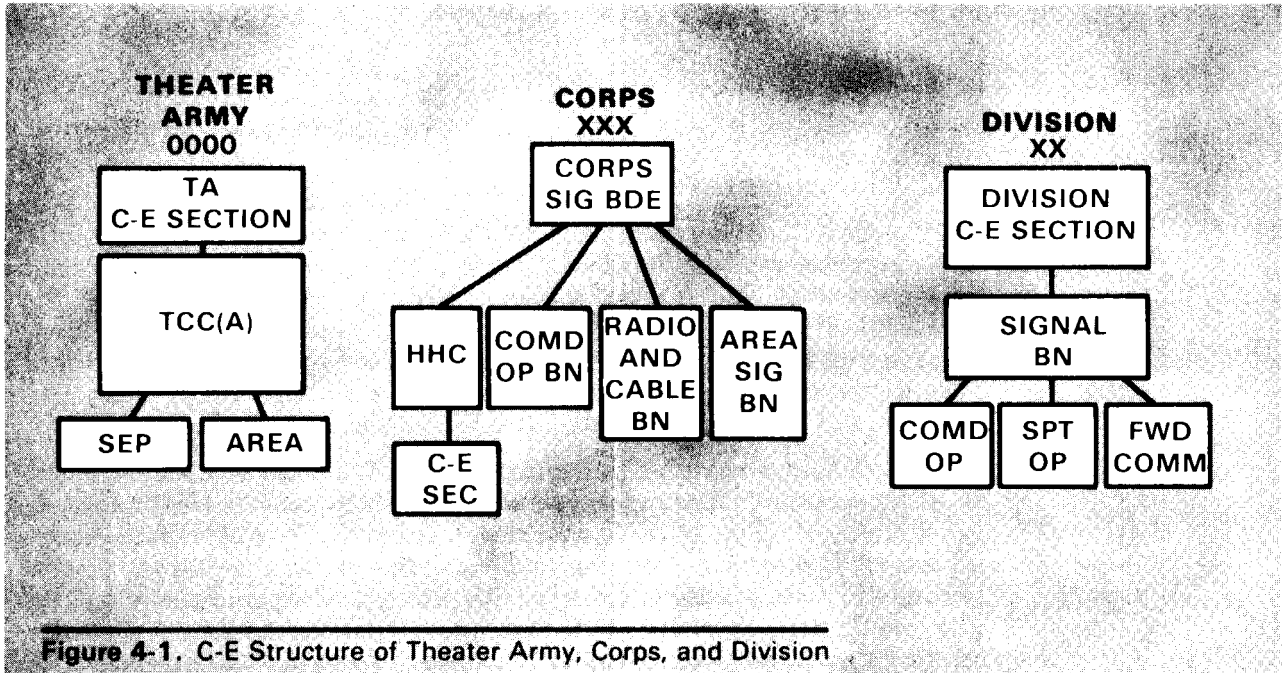

Figure 3-7. Brigade Communications System

### **3-6. Brigade Communications System**

The brigade communications system functions as an integral portion of the overall division communications system and serves as its forward terminus. The brigade headquarters is connected with the main echelons of the division by multichannel radio and/or cable provided and operated by division signal battalion personnel. Forward area signal centers of the division provide communications links between brigade and combat support and combat service support units. RATT sets are used in the brigade area to operate in the division RATT nets to supplement and back up the division multichannel system.

FM single channel radio nets are established in the brigade area and between the division and brigade. These radios are the primary means of communications during the heat of battle when instant reaction to orders is essential to the outcome of the battle.



#### 4-1. Introduction

The tactical communications-electronics management system consists of the C-E management assets assigned to each echelon. Each level of command is responsible for integrating its own communications into the system and for supporting the overall system within the theater of operations. The representative organizational structure (fig 4-1) is described in this chapter. Note that this manual discusses only the relationship between theater and theater army C-E management functions. It does not prescribe doctrine for the theater.

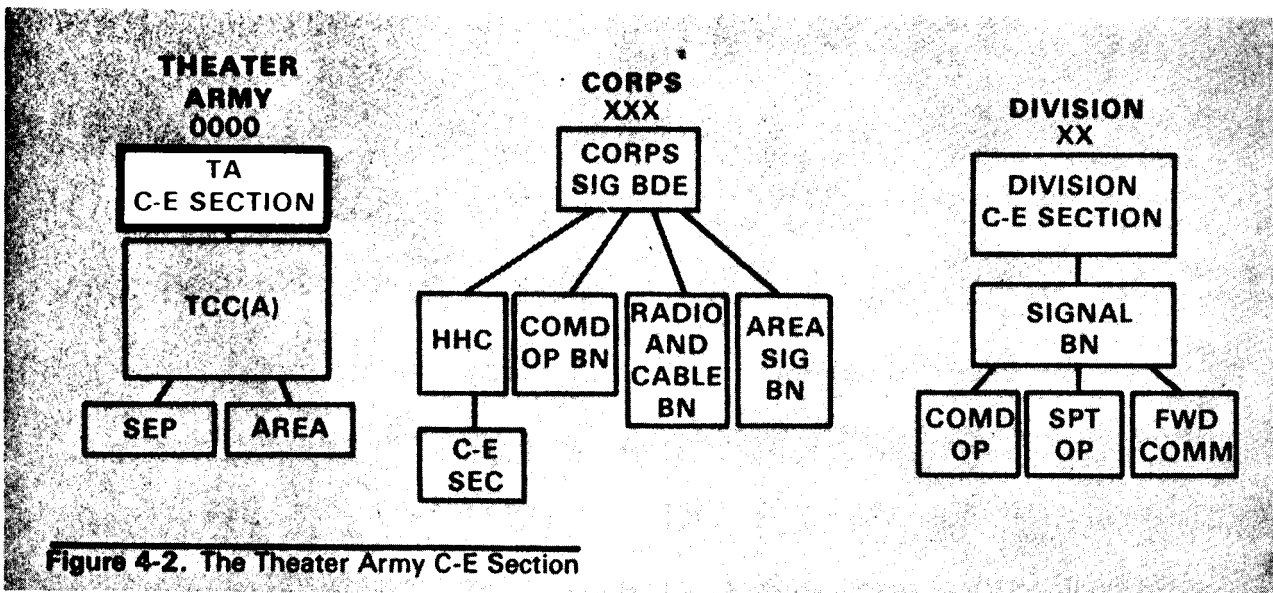

Figure 4-2. The Theater Army C-E Section

## 4-2. Theater and Theater Army C-E Management

a. The theater commander is responsible for communications of the theater headquarters and from the theater headquarters to and between component services within the theater of operations. He normally delegates the responsibility for signal communications support to the major component commander and to commanders of joint task forces. In a large theater of operations, the theater commander may delegate the responsibility and function of COMMZ communications to the theater army commander.

b. The theater army (TA) commander depends on his assistant chief of staff for communications-electronics (ACSC-E) for recommendations on C-E requirements. The ACSC-E, also known as the TA C-E officer, is in charge of the TA C-E section. He is responsible to the commander for the overall formulation and implementation of C-E plans, policies, and procedures for the installation, operation, maintenance, and management of the theater communications system (army) (TCS(A)). As the commander's primary C-E adviser, he forms broad policies for C-E activities and issues instructions for their implementation to major subordinate commanders. The TA C-E section is the primary point of contact for coordination with the joint forces commander, CONUS activities, and other activities concerning communications-electronics matters. Under the tactical communications control facility (TCCF) concept, the C-E section is the CSPFE for the theater army. Personnel from the C-E section man the theater army tactical automatic switch control office (TASCO) along with personnel from TA signal brigade CSPE and CSCE offices. The C-E section is composed of two divisions:

(1) The Plans Division consists of three branches:

- The Electronic Warfare Electromagnetic Environment Branch.
- The Frequency Management and Call Signs Branch.
- The New Equipment Training Branch.

(2) The Operations Engineering Division consists of three branches:

- The Operations Branch.
- The Engineering Branch.
- The Systems Performance Analysis Branch.

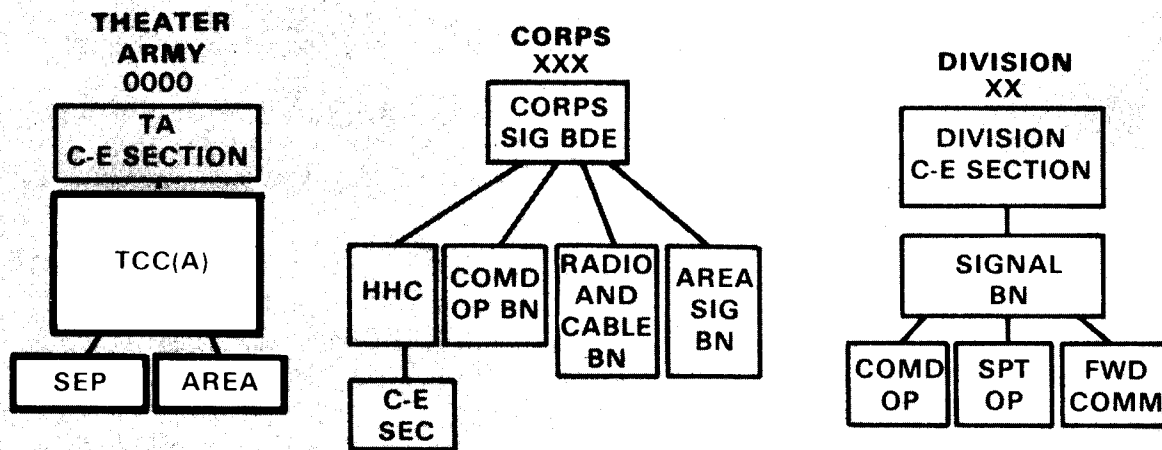

**Figure 4-3. The Theater Communications Command (Army)-TCC(A)**

### 4-3. Theater Communications Command (Army) (TCC(A))

a. The TCC(A) installs, operates, and controls the theater communications system (army) (TCS(A)) which provides both command and area type communications. Within the theater army, subordinate units of the TCC(A) provide a high capacity, multimedia, multiaxis, integrated communications network. TCC(A) provides command and control of assigned or attached signal units. Headquarters, TCC(A), provides the CSPE and CSCE functions for—

Planning.

Systems engineering.

Traffic engineering.

Circuit allocation and control.

Communications security (COMSEC).

Liaison with the—

Defense Communications Agency

C-E staffs of other military services.

Allied forces.

Civilian communications agencies.

b. The TCC(A) is responsible for the COMMZ line of communications (LOC) from the rear of the COMMZ to the rear of the combat zone. The TCC(A) employs the assets of the separate companies or battalions plus area companies and battalions that are assigned or attached. Representative types of units used are operations battalions with multichannel facilities, trunk switching companies, communications center operations companies, and tropospheric companies; as well as other specially organized units tailored to provide theater army C-E support.



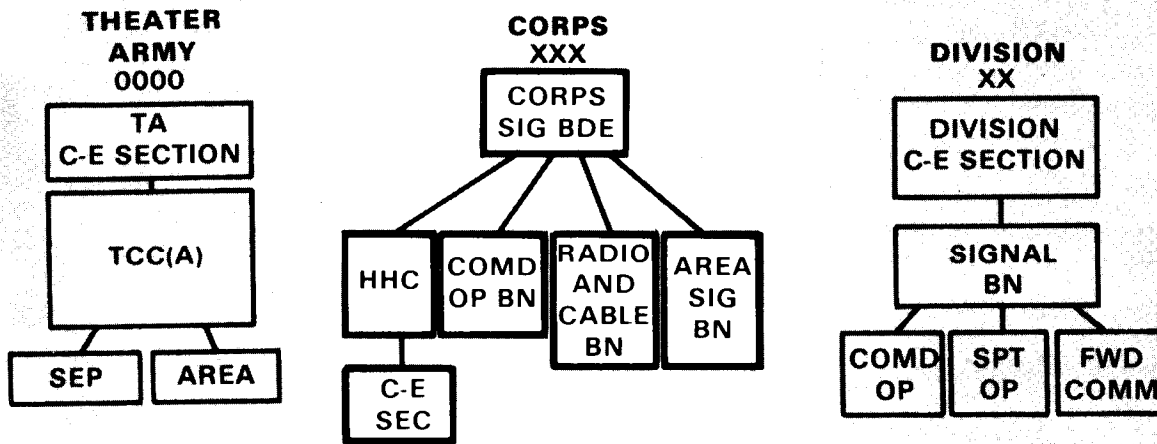

**Figure 4-4. The Corps C-E Management**

#### 4-4. Corps Level C-E Management

a. Corps C-E Officer/Signal Brigade Commander. The corps C-E officer is a member of the special staff of the corps headquarters. He is also the commander of the corps signal brigade. In both functions, he is the key individual in the C-E management system at the corps level.

b. Corps C-E Officer Functions. In his functions as the corps C-E officer, the signal brigade commander has staff responsibility for the coordination and supervision of the activities of all corps communications systems. His special staff responsibilities are to—

- (1) Advise on communications-electronics matters including signal communications, locations of headquarters, and signal facilities.
- (2) Determine requirements for communications support and the employment of signal troops.
- (3) Exercise technical staff supervision over C-E activities of the commander.
- (4) Prepare the C-E and electronic counter-countermeasures (ECCM) portions of the training program.
- (5) Coordinate frequently allocation, frequency assignment and use, and the reporting and processing of interference problems.
- (6) Advises the commander and staff on matters pertaining to electromagnetic radiation environments in the command.
- (7) Evaluate technical instructions; obtain advice and assistance from C-E staff officers at higher echelons; coordinate plans and operations with the C-E staff officer of higher headquarters; and provide technical advice and assistance where needed.
- (8) Represent the corps on planning groups to assure proper consideration of C-E support.
- (9) Assist in preparation of electronic warfare (EW) plans and annexes.

(10) Implement the signal security policy and procedures.

(11) Plan and coordinate the installation, operation, and maintenance of communications systems by assigned or attached units.

(12) Plan and coordinate still and motion picture photographic services.

c. Corps Signal Brigade Commander Functions. The signal brigade commander (also the corps C-E officer) controls all assigned and attached signal units. He directs the installation, operation, and maintenance of corps C-E systems and facilities required to implement plans developed by the corps C-E staff to include—

(1) Communications system planning, engineering, and control functions.

(2) Technical control over all corps communications facilities.

(3) The communications systems of major subordinate commanders and adjacent major US and allied commands with the communications systems established by the brigade.

(4) Crypto logistics support coordination for the corps.

(5) Coordinating support required for access to the theater army communications system.

d. Headquarters and Headquarters Company (HHC) of the corps signal brigade provides the staff personnel who—

(1) Are responsible for command control, staff planning, and supervision of signal brigade operations for the commander.

(2) Form an element to plan, engineer, and control the corps command and area communications systems.

(3) Make up the corps C-E section that supports the corps staff.

e. Corps C-E Section. Although this section is assigned to the HHC of the corps signal brigade, its duties are performed at corps headquarters under the direction of the C-E officer. The C-E section is used by the corps C-E officer in the coordination, planning, and technical supervision of the corps communications systems. The CSPE and CSCE functions performed either by the C-E section at corps or by the operations section of the signal brigade are—

(1) Long range communications planning.

(2) Contingency planning.

(3) Communications network layout.

(4) Preparing the technical annex to theater army plans and orders.

(5) Analyzing the operation of all corps systems.

(6) COMSEC.

(7) Issuing and controlling radio frequencies and call signs.

(8) Preparing radio net diagrams.

(9) Coordinating on frequency matters with the theater army C-E section and subordinate commanders.

f. CSCE, CNCE, and CESE. The functions of these elements are provided by elements of the corps battalions as described below.

(1) The corps command operations battalion provides terminal communications facilities (telephone, teletypewriter, facsimile, and air

and motor messenger service) for the echelons of corps headquarters. It also shares a responsibility with the radio and cable battalion for displacement of the corps command posts communications facilities.

(2) The corps area signal battalions (normally four) are charged with installing, maintaining, and operating the corps area communications system which provides the multichannel radio and cable communications for the combat support and combat service support units within the corps area. Further, the corps area communications system serves as an alternate means of communications for the corps headquarters command system.

(3) The corps radio and cable battalion controls the attached signal elements of the brigade and the single channel and multichannel transmission facilities in the command communications system. It provides cable and wire support to the command communications system and shares command post displacement responsibility with the corps command operations battalion.

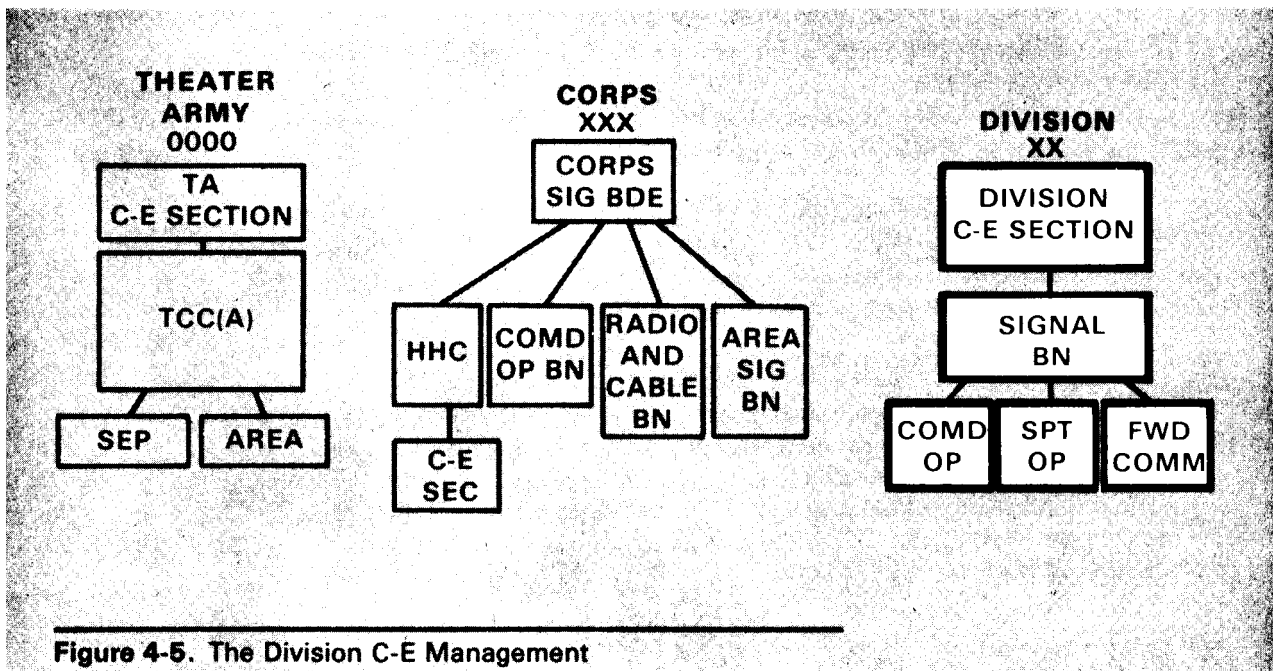

Figure 4-5. The Division C-E Management

#### 4-5. Division Level C-E Management

a. Division C-E Officer/Signal Battalion Commander. The division C-E officer is a division staff officer. He also commands the division signal battalion. He directs all signal activity within the division and is the key individual in the C-E management system at the division level.

b. Division C-E Section. The C-E section is also the CSPE for the division. Based upon input from the various division staff elements, it performs the following functions.

Determines communications requirement.

Engineers communications systems.

Integrates C-E plans with tactical operations.

Prepares diagrams and map overlays.

Insures COMSEC practices.

Provides the signal battalion S3 with direction and guidance for establishing the division communications system.

**c.** The Division Signal Battalion provides signal communications systems and facilities for all command echelons of a division, together with special staff and technical assistance for planning and control of all division communications. It is staffed to provide direct support COMSEC logistics for the division. The operations section of the battalion HHC performs the division CSCE functions.

**d.** The HHC of the organic division signal battalion, together with the communications-electronics staff plan, direct, and coordinate assigned operations and required training of the division signal battalion. HHC also provides command, control, administrative, and logistical support for the battalion.

**e.** Signal Companies of the division signal battalion install, operate, and maintain the communications facilities of the division as follows:

**(1)** The command operations company ("A" company) provides communications facilities and services for the division main, division tactical command post, division artillery, and artillery group.

**(2)** The forward communications company ("B" company) provides three forward area signal centers to support units within a designated forward area of the division. The company also provides secondary access to the division communications system for supported units in the immediate area. The company provides the multichannel access for the brigades of the division.

**(3)** The signal support operations company ("C" company) provides communications facilities for a division support area (DSA). It also provides signal center support for units near the DISCOM headquarters or near the division rear elements; and multichannel service to the ADA, engineer battalion, and the division aviation unit.

**f.** Unit Communications Officers of brigades and separate battalions perform duties similar to the duties of the division C-E officer. Generally, the duties include—

**(1)** Supervising the installation, operation, and maintenance of the unit's communications system.

**(2)** Preparing plans for displacement or extension of the communications system.

**(3)** Supervising the maintenance of communications security and assisting in preparing training directives pertaining to communications.

**(4)** Preparing standing operating procedures (SOP) required for tactical and technical control of the communications system.

**(5)** Assisting in the selection of the locations of the command post and communications installations within the command post.

# C-E Planning



## 5-1. Introduction

Under the C-EMS structure, the C-E plans—and engineering—result from the staff planning methods used to develop C-E (signal) estimates and plans. At the higher levels of the command structure particularly, the C-E plans and orders developed provide only general guidance in the scheme of C-E support.

This chapter covers the functions involved in the C-E planning process. The list of functions presented here may be used as a planning guide for using communications resources, to include the installation, operation, and maintenance of C-E systems that satisfy user requirements. The planning functions involve responsibilities at all echelons; only their scope changes according to the planning needs of each command level. Additional information on C-E planning, procedures, and formats is in FM 24-16.



## 5-2. Relationship Between C-E Planning and Engineering

General guidance is of little value to the equipment team installing a circuit; therefore, at some point, planning must become engineering and provide detailed technical information. At that point, a detailed C-E (signal) order must be issued to activate the C-E system. The C-E order must satisfy the needs established or determined during the planning phase.

a. The amount of technical detail contained in the C-E order will vary with the level at which it originates; the higher the echelon in the organizational structure, the less the required detail. Even at the implementing level, C-E orders may not be specific if SOP's and other fixed directives are available and provide detailed implementing instructions. Obviously, if the C-E system can be activated with a simple, easily understood order, the communications needs of the supported command are more effectively satisfied. For this reason, standard procedures, preplanned interface, and standing instructions are established.

b. Specific functions of the planning elements are as follows:

- Preparation of C-E plans, estimates, and orders.

- Maintenance of records.

- Assessment and allocation of resources.

- Validation of user requirements.

- Preferential services.

- Issuing technical directives.

- Introduction of new equipment.

- Frequency management.

- Assignment of call signs.

- Contingency planning.

- Recording user locations.

- System security.

- Provision for messenger service.

- Directory service.

c. Engineering functions may be identified as distinct from planning functions but, in reality, are often inseparable from planning. Engineering functions are listed here to show their relationship to planning and are covered in detail in chapter 6.

- Network layout.

- Traffic engineering and diagrams.

- Circuit routing lists/bulletins.

- Traffic diagrams/bulletins.

- Line route maps.

- Multichannel systems and radio net diagrams.

- System performance analysis.

- Electronic counter-countermeasures.

Figure 5-1 shows a logical progression of planning and engineering functions.

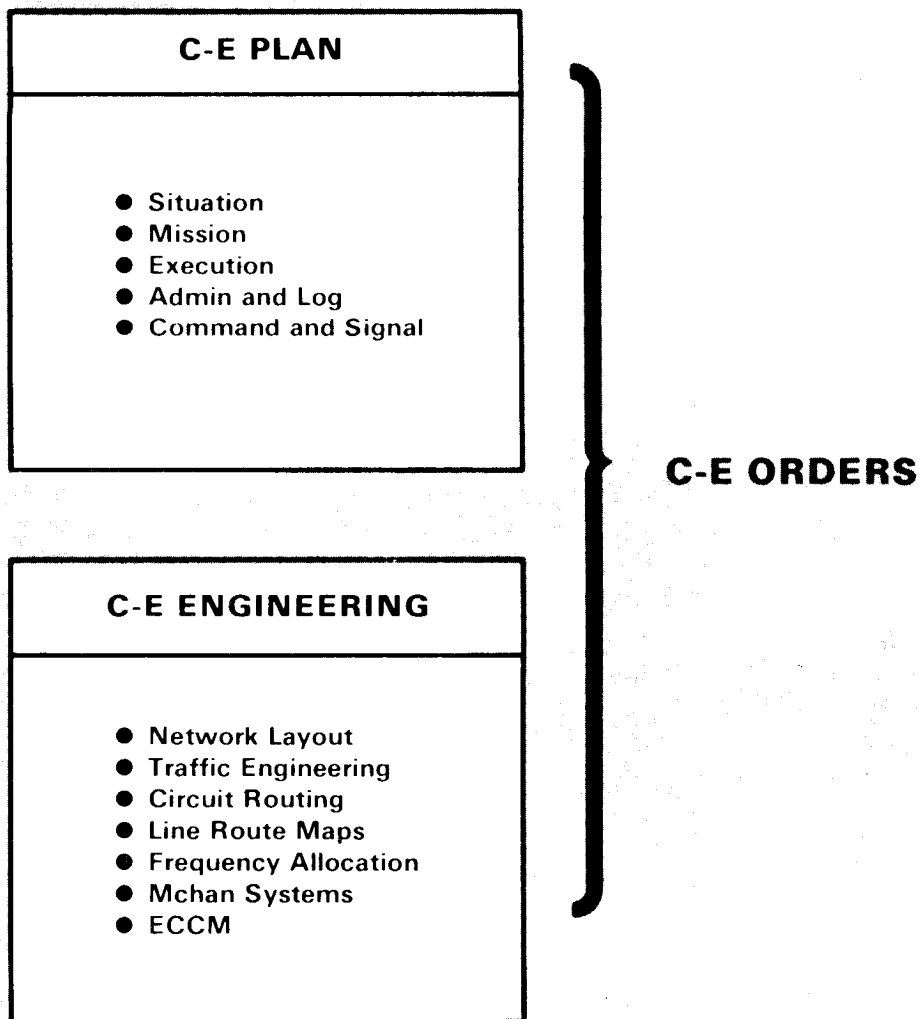

**Figure 5-1.** Progression of Planning and Engineering Functions

### 5-3. Preparation of C-E Estimates, Plans, and Orders

**a.** The C-E estimate is a continuing process that is seldom recorded, except at high command levels. However, if time permits, estimates may be kept at any level and used in preparing plans for future operations. Revision of the C-E estimate occurs constantly as new facts are introduced.

**b.** The C-E plan is based on paragraph 5 of the C-E estimate. It contains instructions and information about providing C-E support for the command as a whole. Specifically, the C-E plan—

- (1) Assesses the situation.
- (2) Defines the mission.
- (3) States the proposed method of execution.
- (4) Lists the administrative/logistical plan.
- (5) Lists the C-E instructions in effect and location of command posts.



c. C-E orders are combat orders that govern the installation, operation, and maintenance of the C-E facilities and systems that support strategic and tactical operations. They include the C-E portion of command operation orders, C-E operation orders, standing operating procedures (SOP), communications-electronics operation instructions (CEOI), diagrams, maps, overlays, and sketches—all of which are required for effective management and operation of the C-E system. The C-E orders are issued in the same format as the C-E plan and include annexes as needed for supplemental information.

d. SOP's and CEOI's are issued as needed and according to FM 24-16.

(1) SOP's cover those features of operations that lend themselves to a definite or standardized procedure without loss of effectiveness. In the absence of specific orders to the contrary, compliance with SOP is required. The major command staff will publish an SOP to provide instructions for those operations or activities that are considered normal and routine. The staff will also publish one for those situations that require rapid reaction by the command when the situation may not permit the issuance of any other instructions. These instructions may be included in the communications portion of the command SOP. The C-E officer also develops an SOP for his section to facilitate planning

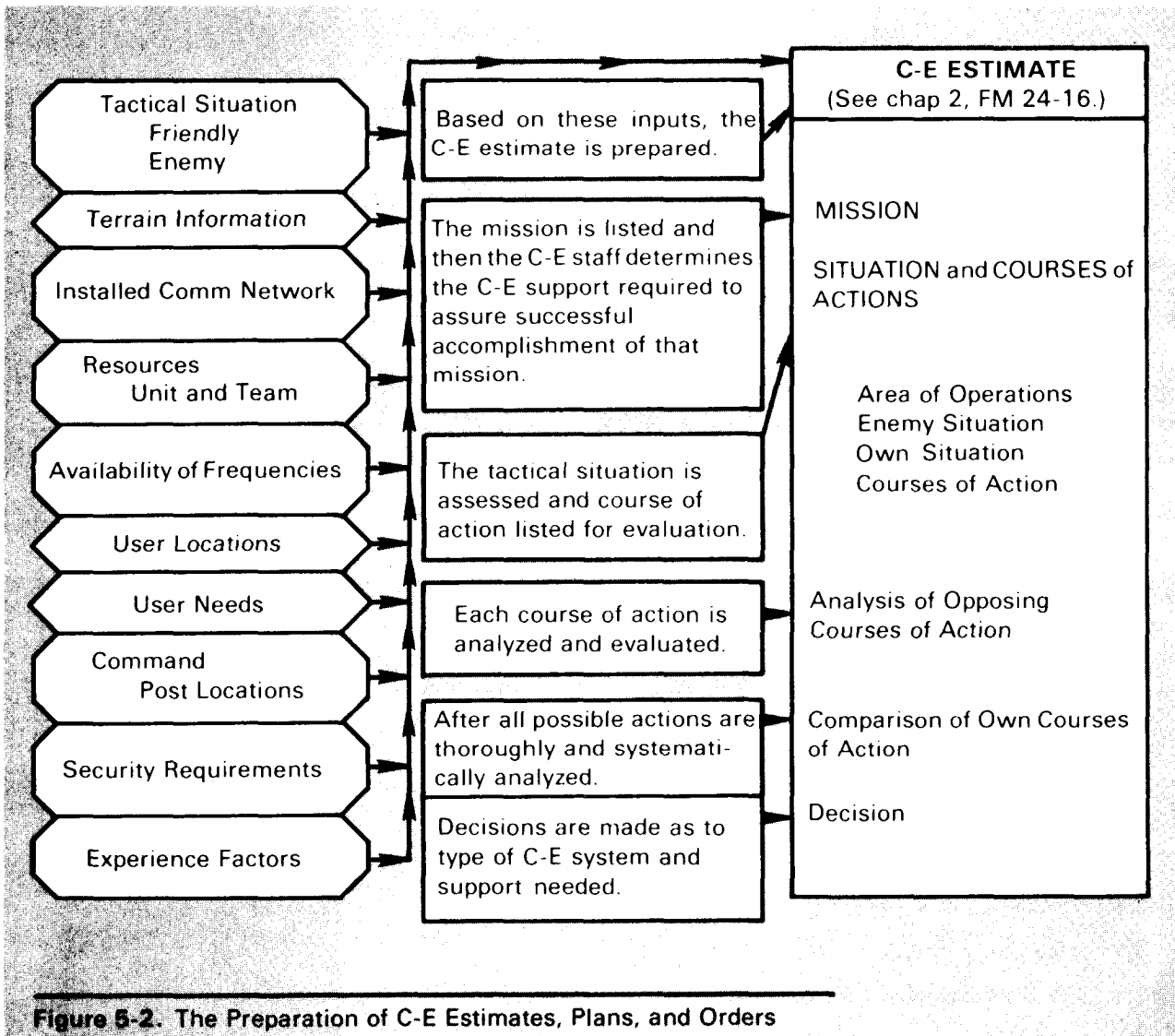

Figure 5-2. The Preparation of C-E Estimates, Plans, and Orders

and operations, and to insure that all elements of the section are aware of their assigned responsibilities and instructions. The senior signal unit and each of its subordinate units will prepare SOP's to provide instructions for the operation of each unit. Normally, the further down the line in echelon and operational level, the more detailed and specific the SOP becomes.

(2) The CEOI contains a series of instructions issued for technical control and coordination of communications-electronics operations of a command or activity. The automated CEOI is prepared and published by the Director, National Security Agency (NSA), and shipped directly to the COMSEC custodian of each command. Manually prepared CEOI's are produced locally. (See AR 105-64.) Subordinate C-E officers determine the distribution of CEOI items within their units and distribute the CEOI extracts required by their commands or units.

#### **5-4. Procedures**

a. The preparation of C-E estimates, plans, and orders closely parallels the planning and decision-making cycle followed by the commander and his staff. For a specific operation, this cycle starts with a mission statement, a commander's concept, and a command estimate; progresses into a command operations plan; and ends with the issuance of a command operations order. The C-E officer and his staff participate directly in the development of command estimates, plans, and orders. C-E estimates are developed to assist the commander in his overall estimate of the situation.

b. During the planning phases, the C-E officer advises the commander and other members of his staff on the capabilities and limitations of the available C-E support and develops a signal plan for each tactical plan. The C-E officer develops the instructions and information pertaining to the provision of signal support for the command as a whole, as well as administrative and logistics information to be incorporated into the command operations order. The C-E estimates, plans, and orders prepared by the major command should be concerned primarily with policy direction, operations, concepts, systems objectives, and special communications requirements for the use of the senior supporting signal units and subordinate major commands.

c. Remember that for the C-E system to function properly, it must be planned properly. And for it to be planned properly, there must be a free and continuous flow of information between the C-E staff and the CSCE.

d. After estimates have been made, plans developed, and orders written, the orders are published, distributed, and implemented.

#### **5-5. Maintenance of Records**

a. Records pertaining to C-EMS functions will be kept in accordance with AR's 340-2 and applicable 340-18 series. Table 5-1 is a summary of the types of C-EMS records normally retained by the C-E section at major command headquarters and at senior signal units. The records may be in the form of documents, cards, messages, diagrams, overlays, photographs, or whatever form that can be best utilized and maintained. C-EMS records will be standardized in both format and content. Records are retained according to procedures established by each major command. Table 5-2 is an example for corps.

b. Permanent records will not be maintained by signal organizations below TCC(A) and signal brigade levels. Permanent records for corps and division will be incorporated into the records of their respective major commands. Within a theater of operations, permanent records of C-EMS operations pertaining to system status and performance, use of equipment and supplies, personnel and training, experience data, and user requirements will be centralized at theater army level or the senior combat zone command. When required, theater army or the senior combat zone command will supply information derived from these permanent records to CONUS. The report is called the Communications System Information Summary.

### Summary of Records

<b>C-E ESTIMATES &amp; PLANS</b>	Issued at all echelons IAW instructions and guidance from higher headquarters.
<b>C-E ORDERS</b>	Normally issued as the C-E annex to the operations orders of the command or of the senior signal unit.
<b>CIRCUIT ROUTING CHARTS/ BULLETINS</b>	Prepared by C-E staffs for issue to subordinate units.
<b>TECHNICAL DIRECTIVES</b>	Issued at all echelons as implementing instructions for the provision of service, network changes, or imposition of restriction measures.
<b>CSCE/CNCE LOGS</b>	Record of system or nodal operational events, including information related to reporting, restoration of service, and ECCM.
<b>TELEPHONE DIRECTORY</b>	Published by major commands for use in their command and area systems.
<b>CIRCUIT RECORDS</b>	Maintained by operating facilities at each node (CNCE, CESE).
<b>COMSEC RECORDS</b>	Maintained by COMSEC section at all levels.
<b>REPORTS</b>	Information which originates at communications nodes and includes such key reports as: operational resources reports, trouble reports, activation/deactivation reports, traffic status reports, and special communications authorization requests.
<b>SPECIAL REPORTS</b>	Unstructured reports which indicate compliance with or implementation of technical directives, special orders, etc.

**Table 5-1. Summary of Records**

**Legend:**

- (S) = short term retention—retained only through completion of the required implementation actions or only as long as the service continues to be provided. Most area company level CNCE records are in this category.
- (M) = mid-term retention—retained 60 days. Area battalion level CSCE records are normally in this category.
- (L) = long-term retention—retained for periods up to 180 days. C-EMS records of a signal group fall in this category.
- (I) = Indefinite retention—C-EMS records for purposes such as broad planning, trend analysis, performance analysis, or historical reference are retained for an indefinite period. Records of TCC(A) and signal brigade are in this category.

Item	Originator/ Recipient	Action	Retention Category
Operational Resources Record	Co HQ/CNCE	Send to Bn HQ daily; log entry .....	S
	Bn HQ/CSCE	Review; send consolidation to brigade HQ daily .....	M
	Bde HQ/CSCE	Consolidate and review. Send monthly summary to C-E Sec .....	M
	C-E Sec	Review; retain for system performance analysis .....	L
Trouble Record	CNCE	Send to Bn CSCE; log entry .....	S
	Bn CSCE	Log entry; issue restoration instructions or forward to Bde. .... CSCE major outages and interference reports	S
	Bde CSCE	Log entry; issue necessary restoration instructions; forward. .... interference reports to C-E Sec; file for historical summary	M
	C-E Sec	Review interference reports for corps frequency action or .....	L
Activation or Deactivation Record	CNCE	Send to Bn CSCE; log entry .....	S
	Bn CSCE	Log entry; forward to Bde CSCE responses to Bde technical directives; record in circuit routing chart/bulletin	
	Bde CSCE	Log entry; record in circuit routing chart/bulletin .....	M
Traffic Status Record	CNCE	Reviews and sends to Bn CSCE daily; log entry .....	S
	Bn CSCE	Log entry; review and forward node reports to Bde CSCE	
	Bde CSCE	Log entry; distribute to Traffic Br; send weekly summary to .....	M
	C-E Sec	C-E Sec; file for historical summary quarterly Distribute to Traffic Br; retain for system performance .....	L
Special Communication Authorization Request	Co HQ/CNCE	Review and recommend to Bn CSCE; log entry .....	S
	Bn HQ/CSCE	Approve if within installed resources and notify Co HQ; .....	M
	Bde HQ/CSCE	Review and approve if within available resources and notify. .... CSCE concerned. Otherwise forward to TA for approval. Retain for historical summary	L
	C-E Sec	Review and approve. Issue technical directive .....	I
Circuit Records	CNCE	Maintain circuit cards for circuits at nodes and extension .....	S
	Telephone/Teletype- writer/Data Switch	links Maintain record of node subscribers .....	S
Telephone Directory	C-E Sec	Prepare and publish. Provide updates monthly; distribute .....	L
	Bde CSCE	to Bde units	
	Bn CSCE	Distribute to Bn HQ .....	S
	CNCE	Distribute to nodes Implement in directory service .....	S
CNCE/CSCE Logs	CNCE	Retain .....	M
	Bn CSCE	Retain .....	L
	Bde CSCE	Retain .....	L
Circuit Routing Lists/ Bulletins	Bde CSCE	Prepare and update. Distribute to Bn CSCE .....	L
	Bn CSCE	Distribute extracts to nodes; update as changes occur .....	M
	CNCE	Log entry; implement .....	S

**Table 5-2. Records Keeping: Corps**

Item	Originator/ Recipient	Action	Retention Category
Technical Directive	C-E Sec	Prepare directives to brigade headquarters .....	L
	Bde HQ/CSCE	Prepare work orders for issue to Bn HQ .....	M
	Bn HQ/CSCE	Prepare work orders for Co HQ .....	S
	Co HQ/CNCE	Issue verbal instructions to platoon HQ or CNCE; log entry .....	S
	CNCE	Circuit card entry .....	S
C-E Estimates/ Plans	C-E Sec	Prepare and distribute within headquarters and to signal brigade .....	I
	Bde HQ/CSCE	Prepare brigade plan and distribute to Bn HQ .....	I
	Bn HQ/CSCE	Prepare Bn plan and distribute to Co HQ .....	L
	Co HQ/CNCE	Prepare node plan .....	M
C-E Orders	C-E Sec	Prepare signal annex to HQ operations orders .....	I
	Bde HQ/CSCE	Initiate circuit and traffic engineering; issue C-E operations orders and technical directives to Bn HQ .....	L
	Bn HQ/CSCE	Prepare work orders for Co HQ .....	M
	Co HQ/CNCE	Issue instructions to platoon HQ or CNCE; log entry .....	S
	CNCE	Circuit card entry .....	S

Table 5-2. Records Keeping: Corps cont'd

## 5-6. Assessment and Allocation of Resources

To meet the communications needs of force deployment in the best possible way, C-E requirements must first be evaluated. Then, available resources are allocated to satisfy valid needs to the greatest extent possible.

a. Resources, in the C-EMS context, include communications equipment with associated power generators and vehicles; communications operations, planning, and engineering personnel; frequencies and systems facilities, such as channels, trunks, subscriber terminal equipment; and messenger service.

b. Assessment and allocation are performed at all levels where responsibility for systems planning and engineering, control, and operations are performed, and are continuing processes. All signal unit commanders are responsible for assessing and allocating their resources under the guidance and policy of the major commander. Commanders must know the relationships between personnel and crew-served equipment configurations.

c. A data base is established and maintained to provide accurate and timely information about the status of resources and proposed network changes. It is periodically updated, preferably daily, by node or facility commanders who report to the controlling CSCE. The data base is not necessarily computerized, although it probably will be. It is used—

- (1) To determine the availability of personnel and the operational status of equipment for establishing systems.
- (2) For extension or reconfiguration of systems.
- (3) For restoral action after damage to the network.

d. Communications resources status information will be maintained in CSCE data bases for use by major C-E staff sections and signal unit commanders. The data base includes information on—

- (1) Personnel/equipment teams status.
- (2) Available stocks of selected critical items.
- (3) Maintenance levels.
- (4) Communications specialists in theater training.

(5) Resources in transit.

(6) Status of organic communications resources of nonsignal units.

e. The CSCE supporting a signal unit makes recommendations on the allocation of resources based on system status, anticipated requirements, current and projected availability of resources, and the major command priorities. However, the controlling signal commander actually does the allocation using signal orders, technical directives, and similar documents as a guide. Allocations are normally made in response to—

(1) Trouble reports.

(2) User communications requirements.

(3) Orders from higher headquarters.

f. While priorities for resources allocation are a command decision based on operational necessity, the key thought in allocation is economy of resources. Two important factors that relate to the economy of resources are—

(1) Alternate systems must be kept to a minimum. Maximum use of channel capacity must be accomplished by using common-user circuits.

(2) The allocation of dedicated circuits and subscriber terminal equipment—over normal SOP distribution—must be closely monitored.

## **5-7. Responsibilities for Assessment and Allocation**

a. For assessment and allocation to be fully effective, guidelines must be established by the headquarters of the highest echelon signal organization. The guidelines should delineate—

(1) Responsibilities.

(2) Delegation of authority to commit resources.

(3) Issuance of specific instructions as to the extent a unit may expend its capability (including the numbers and types of teams for which commitment may be made without referral to the next higher headquarters). This applies particularly to system restoral actions executed on the basis of system integrity and operational priorities.

b. To insure adequate responsiveness and flexibility in providing communications support, the extent of the commitment of communications resources by the next subordinate command will be established by each command echelon. The extent of commitment will be between 80 and 90 percent of available resources. Authority to commit resources to the threshold level should apply both to installed and uncommitted equipment and to personnel. When requirements for resources cross command lines, the decisions will be made by the headquarters with control over the unit involved.

c. In planning for the effective employment of the allocated resources, the time element is a major governing factor, especially where restoral action is concerned. Calculations for restoral of service must consider the point of availability of the resources and travel time to the point of installation. For example, a shelter in a transportable configuration may be removed from its prime mover and transported by heavy lift helicopter, while the organic vehicle proceeds to the site by road.

## **5-8. Validation of User Requirements**

a. A tactical communications system must be designed and operated only within unit capabilities and only in direct response to the tactical mission.

Unit commanders and their staffs must neither request nor plan upon a communications system that exceeds the primary needs of the unit. Basic user (unit) requirements for communications are broadly prescribed in Army doctrinal publications and are reflected in the basis of issue (BOI) of terminal equipment authorized for user units. User requirements are also reflected in the amounts and capacities of switching and transmission equipment authorized for signal units providing C-E support.

**b.** The planning and engineering of a communications system for maximum effectiveness within available resources require precise identification and validation of user requirements.

(1) In the command communications system, most requirements are fixed, known in advance, and subject to little change.

(2) In the area communications system, requirements for common-user support are not as fixed as in the command system. Requirements will vary with troop deployment and changes in support of unit locations.

(3) The theater army C-E section will identify requirements for basic communications circuits and for support of the army in the field. The section will publish these requirements in an SOP as guidance for major commands and their supporting signal units.

**c.** The types and amounts of access communications to the command, area, and theater systems will be prescribed for the combat, combat support, and combat service support units on the basis of published doctrine, if available, or experience factors. In this way, a baseline network can be designed and installed to satisfy minimum essential user requirements. In addition to baseline requirements, tactical situations and changing environments require that a means be provided for users to obtain changes to their normal communications support when necessary.

**d.** The validation of new requirements begins when the potential user submits a request, either oral or written, to the CNCE supporting the unit involved. The CNCE grants the request if it has the capability and authority. Otherwise, the CNCE prepares a special communications authorization request (SCAR) and submits it to the next higher headquarters and subsequently to the unit with the resources to grant the request. Figure 5-3 shows the procedures for validation of user requirements.

## **5-9. Preferential Services**

Preferential services are provided to users (usually select users) to insure continuity of operations or to improve responsiveness to situations.

**a.** In tactical C-E systems that employ manual switching, preferential services are usually provided either by dedicated circuits or by call supervision by telephone operators. Automatic switches, however, can and do provide preferential service by selective programming; there is no need to use dedicated services or the operator.

**b.** The following are some of the preferential services that can be provided by automatic switches.

(1) Assignment of precedence and preemption capability.

(2) Call forwarding.

(3) Conferencing (preprogrammed, progressive, and broadcast).

(4) Off-hook service (direct access capability (DAC)), sometimes called a hot line.

(5) Assignment of a fixed directory number to selected mobile subscribers.

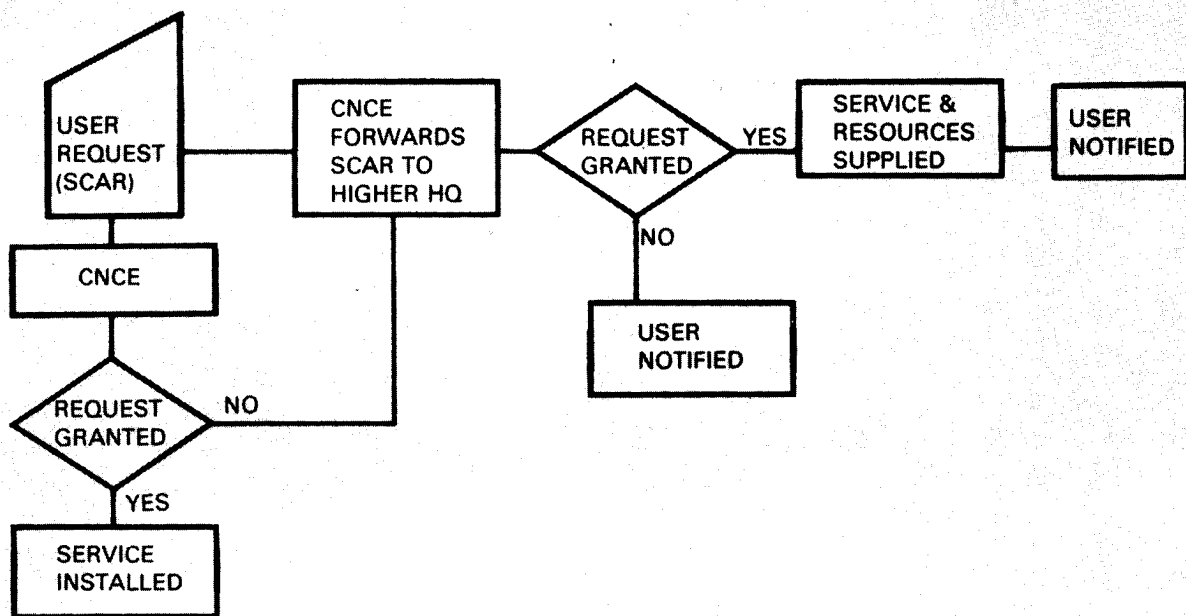

**Figure 5-3. User Request Processing**

c. Since the demand for preferential services usually exceeds the capability of the equipment, the services must be limited to those who really need them. Initial requests for preferential services should be submitted to the system planner during the design phase of the C-E system. After the C-E system is established and as the need arises, a potential user may submit a special communication authorization request (SCAR) to the commander of the node serving the user's organization. The decision on who gets preferential service will be made at the major command level. Authorized preferential services will be included in the SOP of the supporting signal unit and will be reflected in instructions to the CNCE's and automatic switches involved.

## 5-10. Issuing Technical Directives

a. A technical directive is used to initiate, govern, or order a certain action, procedure, or policy. The directive may be either oral or written; the lower the echelon, the more likely they are to be verbal directives.

b. For efficient functioning of the C-E system, there must be an unrestricted flow of technical information between C-EMS elements. Thus, technical directives are issued at all C-EMS echelons (fig 5-4) to provide amplifying instructions on procedures, standards, methods, and techniques used to implement major C-EMS decisions. Directives are also used to assist in system coordination and uniformity of operations. Guidelines on issuing and recording technical directives are as follows:

c. Technical directives are issued by C-E sections of major commands or by CSCE's to subordinate counterparts or signal units. Those directives that



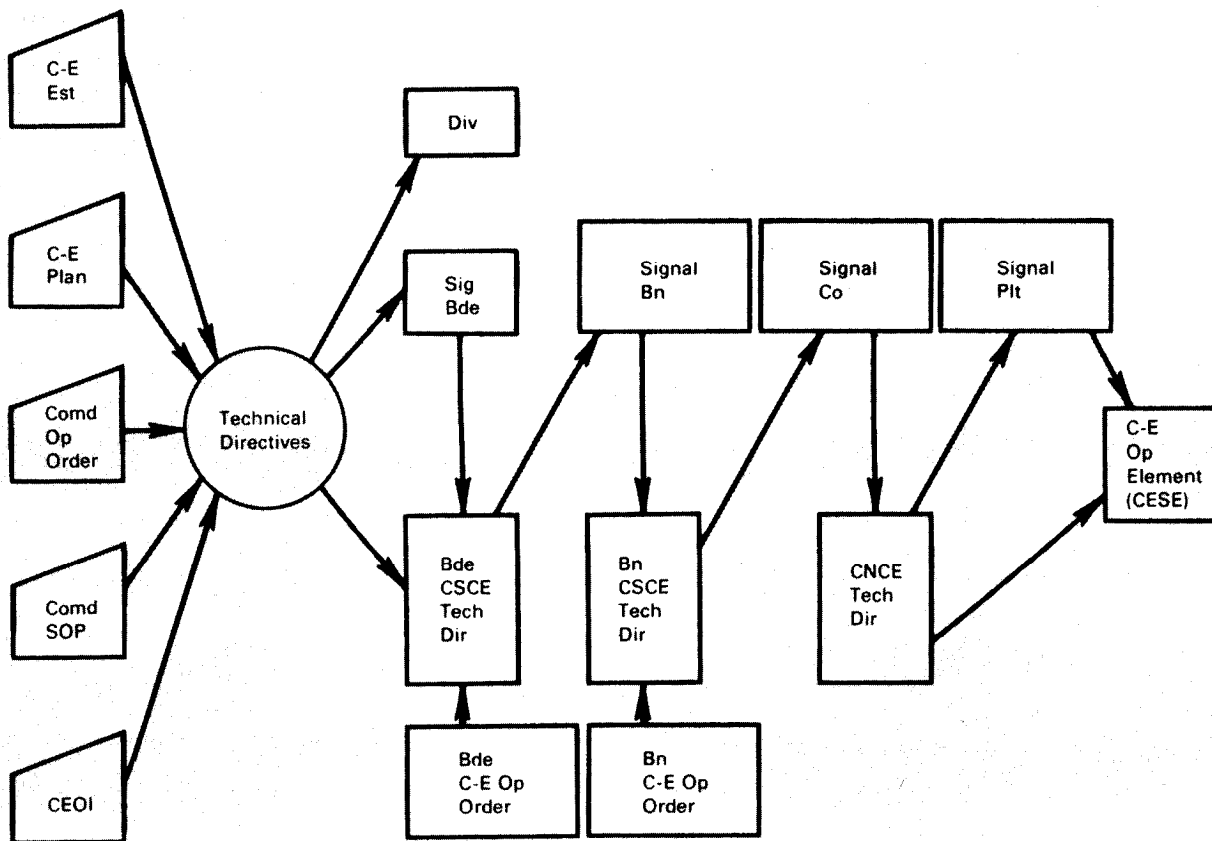

**Figure 5-4. Flow of Technical Directives in the Corps**

deal exclusively with technical C-EMS matters, not of a command nature, should flow through technical channels without regard to major command boundaries and the formal C-EMS structure. Typical technical directives issued within a corps are listed in table 5-3.

d. Technical directives pertaining to the allocation of resources and to changes in formal plans and orders are issued by the corps C-E section and by subordinate signal command echelons, in turn.

e. Technical directives relating to procedures, methods, and techniques are normally issued at the CSCE/CNCE levels. In some instances, they may be issued by the corps C-E section.

f. Certain technical directives are issued and applied under the same general rules that apply to formal orders. For example, some C-EMS directives impact on C-E matters and require authentication by the originating commander or his authorized representative. In this category are:

The allocation of resources.

Changes to command communications plans.

Modifications to command policies and directives.

g. The CSCE and CNCE concerned maintain a Master Station Log, DD Form 1753, to record technical directives issued and received, as well as their disposition.

## Issuing Echelons for Type Technical Directives in the Corps

Directive	Issuing Echelon							
	Corps C-E Sec	Sig Bde	Bde CSCE	Sig Bn	Bn CNCE	Sig Co	CNCE	Sig Pit
1. Telecom Service Orders			x		x		x	x
2. Resource Allocations		x		x		x		x
3. Validation of Communication Requirements	x	x	x			x		
4. Change to Plans and Orders	x	x		x				
5. Circuit Routing List/Bulletin	x		x					
6. Mchan Systems Diag/Bulletin	x		x					
7. Radio Net Diag/Bulletin	x		x					
8. Traffic Diag/Bulletin	x		x					
9. Network Layout-Inst or Changes	x		x					
10. User Locations	x		x		x		x	
11. Patching Procedures or Instructions			x		x		x	
12. Testing Instructions			x		x		x	
13. Restoration Priorities	x							
14. Instructions for Troubleshooting			x		x		x	
15. Security Instructions	x	x	x	x	x	x		x
16. Traffic Handling Instructions	x		x		x		x	
17. Standards for Area Center Layout	x		x		x			
18. Standards of Construction	x		x		x			
19. Frequency and Call Sign Changes	x							
20. Teletypewriter & Data Routing Changes	x		x					
21. Modification of Automatic Switch Data	x		x				x	
22. Restrictive Measures Instructions	x		x		x			
23. Authentication Procedures	x		x					
24. Reporting Procedures			x		x		x	
25. System Lineup Procedures			x		x			
26. Messenger Schedules	x		x		x			
27. Telephone Directory Changes	x		x					
28. Telephone Operator Instructions			x		x			

**Table 5-3.** Issuing Echelons for Type Technical Directives in the Corps

### 5-11. Introduction of New Equipment

To meet the constantly changing needs of the tactical situation, new C-E equipment is continuously being designed, produced, tested, and introduced into the field. The objective is to provide improved technical capabilities in our communications system. In the process, new items must be introduced into the system with a minimum of confusion and disruption of service to users. Normal practice is to keep both the old and the new equipment operating in parallel. This allows continuance of service to the users and, at the same time, provides training time to operators and maintenance personnel. Then, as time—usually a specified time frame—goes by, the old items are withdrawn, evacuated, and either reissued to other

units that need them or packed and shipped to CONUS. Security is of prime importance and every effort must be made to keep the enemy from discovering whatever unique capabilities are provided by the new equipment.

**a. Organizational levels of responsibility.** A primary requirement in the introduction of new equipment is close coordination between CONUS planning personnel and theater army personnel. Shipping schedules, deployment phasing, logistical support, personnel, training, and use of new equipment training teams (NET) from CONUS sources should be closely coordinated. Prior to introducing new equipment, appropriate C-EMS elements should make detailed assessments of the operational characteristics and interface requirements for new equipment and then prepare the necessary changes to C-EMS policies, methods, and procedures.

(1) Theater Army. Within the COMMZ in a theater of operations, the theater army C-E section will control the introduction of new communications equipment.

(2) Corps. Within the combat zone, the corps will handle the introduction of new equipment.

(3) Division. The C-E sections of both corps and division will coordinate the introduction of new equipment for units in their respective commands.

**b. Staff responsibilities.** Each major command C-E staff is responsible for insuring that adequately trained personnel for both operation and maintenance, along with repair parts, special test equipment, and documentation, are available before commitment for operation is given. The major command C-E staffs also provide wide distribution of new equipment phasing-in schedules to insure smooth transition from old to new. As new equipment replaces old equipment, inventory changes must be updated and reported on the operational resources report.

## **5-12. Radio Frequency Management**

Radio frequency resources (channels of the frequency spectrum) are in critically short supply and their use requires closely controlled, proper management. And because radio frequencies are so important, their allocation and assignment is a command function and a command responsibility. Each command must implement effective control procedures to insure that electromagnetic emissions conform to the policies of the higher headquarters.

The essential factors that must be considered in operational planning include frequency requirements and availability, assignment priorities, and geographic and technical limitations. Whenever possible, frequency sharing should be used. This can be accomplished through proper management, control, and training. Careful planning and management is a must to prevent mutual interference or saturation of any portion of the radio spectrum.

## **5-13. International Frequency Control**

Use of the radio frequency spectrum in all countries is governed through the United Nations (UN). The controlling agency of the UN is the International Telecommunications Union (ITU) which, through periodic international conferences, concludes treaties regulating the use of the radio spectrum, obtains standardization of methods and procedures, and minimizes interference. In addition, most ITU member countries impose additional regulatory measures beyond those required by international

treaty. Only those frequencies assigned and approved by the host country are to be used.

a. When the host country for US forces has a controlling government, the allocation of frequencies within that country is under the control of that government. Allocation and use of frequencies are diplomatic matters that are resolved by the heads of state or the official representatives of the governments involved.

b. After a base of operations is established in the host country, the task force commander continues negotiation on frequency allocations with the government of that country.

#### **5-14. Frequency Management Channels**

In all overseas commands involving large geographic areas and employing two or more armed services, a unified command is established—a theater of operations. The major Army, Navy, and Air Force headquarters are component commands within the theater.

Frequency management in an overseas area is under the control of the highest command present. If it is a unified command, the Joint Chiefs of Staff (JCS) provide policy guidance and the theater commander provides guidance to the component commands. Figure 5-5 shows the JCS management channels.

#### **5-15. Theater Level Frequency Management**

The theater commander exercises control over radio frequency usage within the theater through his joint staff. The Director of Communications Electronics (J6) has primary staff responsibility for frequency management in the theater. The office of the J6 includes a frequency management section with a trained frequency management officer as the section chief. He and his staff are responsible for the allocation and assignment of all frequencies used by US forces within the theater or zone of operations.

#### **5-16. Theater Army Frequency Management**

a. Theater Army (J6) Section Functions. The Frequency Allocation and Call Signs Branch, Plans Division, of the theater army C-E section is responsible for summarizing the frequency requirements of all subordinate commands. The branch then prepares frequency allocation lists which are published as the Frequency Allocation and Usage (FAU) list of the unified command. Thus, the branch performs frequency planning, coordinates the use of frequencies, and publishes frequency information to subordinate commands. In performing its functions, the branch participates in frequency planning with both higher and lower commands, and helps to insure that the policies and directives of higher echelons (fig 5-5) are being followed. The Frequency Allocation and Call Signs Branch also maintains records of frequency assignments, including a master list of frequency and call sign allocations and assignments for the entire Army area of operations.

b. Theater Communications Command (Army) (TCC(A)) Functions. The Frequency Allocation Branch of the J-6 section (CSPE) in the TCC(A) manages radio frequencies for the TCC(A). The branch is the primary point of contact in the TCC(A) for all radio frequency assignment actions. The branch coordinates frequency requirements and forwards authorized assignments to TCC(A) operating units. It also maintains records, prepares reports, and initiates all required actions regarding radio frequency matters for the TCC(A).

**NOTE:** In the standard C-E management structure, the TCC(A) ranks as a subordinate command of theater army and receives its frequency allocation through the TA C-E section (J6). In turn, the TCC(A) allocates frequencies to other TA subordinate commands for operation of the TCC(A). managed theater communications system. However, the theater commander may elect to have the Frequency Allocation Branch, TCC(A), perform all frequency management for the theater.

c. Frequency Management Considerations. Higher echelons (fig 5-5) and the host country may impose frequency and frequency related restrictions on theater army. These restrictions, plus those of the TA commander, will, in turn, be reflected in the frequency assignments and allocations to lower echelons. Generally, restrictions are related to the size of the TA area of operations, the requirements of the host country and allied forces, the types and quantities of equipment being operated, the limited frequency spectrum

**U.S. Military Frequency Management Channels**

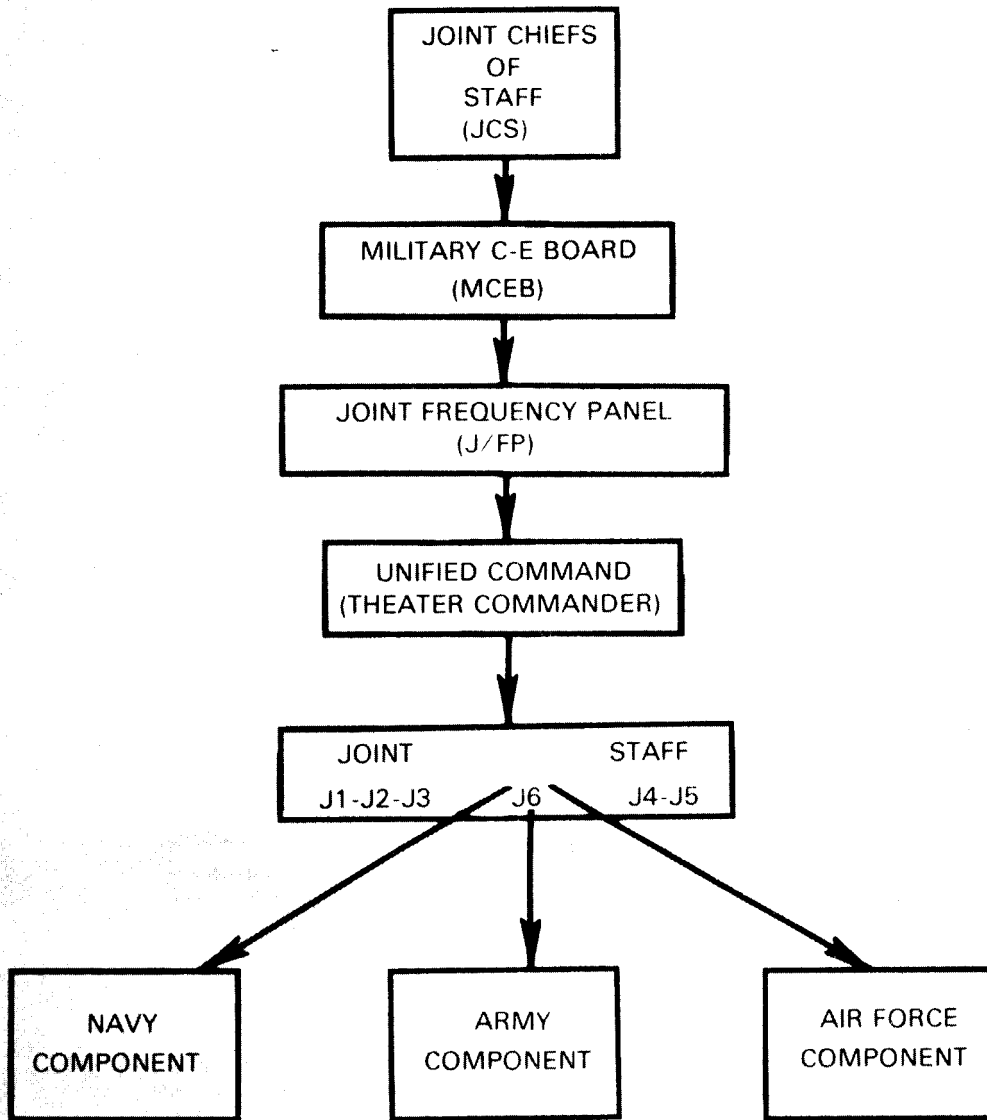

**Figure 5-5.** U.S. Military Frequency Management Channels

available, requirements for strategic communications, etc. The following items are typical of factors that must be considered in frequency management at the theater army level.

(1) Because requirements for tactical FM frequencies will greatly exceed their availability, frequency sharing must be used. The frequency list technique of assignment and allocation and interference charts must be used to avoid mutual interference.

(2) Subordinate TA units must submit justified frequency requirements at least 90 days prior to the date of anticipated use. If this is not possible, current assignments may be used until requests are processed and authorized. The TA commander is responsible for proper use of frequencies.

(3) The higher command will allocate multichannel frequencies to theater army based on the operating frequencies of the equipment used in the theater. Restrictions on multichannel frequencies may be imposed by the host country or because of their use by other US forces and allies in the TA area.

**NOTE:** The ABM plan (FM 24-2) or other effective method of frequency assignment must be applied to obtain maximum use of each available multichannel frequency.

(4) Theater army must obtain individual approval for all HF communications that use skywave propagation or that transmits at more than 500 watts from:

The joint force (theater) commander;

The joint frequency panel (J/FP) of the US Military C-E Board (MCEB);

The Allied Radio Frequency Agency of NATO;

The host country; or,

A representative combination of the above.

(5) For HF communications that transmit at 500 watts or less, theater army must obtain a list of cleared frequencies from the joint force (theater) commander.

(6) For AM air-to-ground, tropospheric scatter, and satellite communications, the joint force (theater) commander or the Department of the Army provides frequency allocations on an individual basis to TA.

(7) The joint force (theater) commander provides a list of authorized FM frequencies (30-76 MHz) to TA. Restrictions imposed by the host country and special operations will be included.

## **5-17. Corps Level Frequency Management**

The corps C-E officer is responsible for providing radio frequency management support to all corps units and coordinates with theater army elements operating in the corps area. The Frequency Allocation Branch of the corps C-E section, under the supervision of the corps C-E officer, performs the frequency management functions. The section consolidates the justified requirements of all subordinate divisions and attached units and submits a request for frequency allocations to theater army. Within the Frequency Allocation Branch, the radio frequency officer, assisted by the area communications chief NCO, coordinates frequency allocations, assignments, and use. His duties include but are not limited to:

a. Coordination of the implementation of the automated CEOI and other directives from theater army.

b. Coordinating frequency allocations and call signs with subordinate commands of the corps.

**NOTE:** When the CEOI is manually prepared, the radio frequency officer is directly responsible for implementing the CEOI and allocating frequencies and call signs, as opposed to a coordinating function. (See AR 105-64.)

c. Representing corps at radio frequency management conferences of higher headquarters.

d. Resolving the interference problems of subordinate units referred to the Frequency Allocation Branch for solution. All problems are reported to higher headquarters.

e. Maintaining records of all frequency assignment within the corps area of operations.

f. Receiving, processing, and forwarding to higher headquarters the radio frequency requirements for all C-E operations in the corps area.

### **5-18. Division Level Frequency Management**

The division C-E officer, who is also the division signal battalion commander, is responsible for frequency management within the division. He supervises the division C-E section which includes a radio officer who, in turn, performs/supervises the frequency management functions as follows:

a. Determining the frequency needs of the division prior to moving into an area of operations. A list of the types and numbers of emitters to be used is submitted to the corps C-E section, along with a request for frequencies.

b. Resolving interference problems within the division. Unresolved problems are referred to the corps C-E section.

c. Making frequency and call sign assignments to assigned and attached units of the division. Assignments are selected from the list of frequencies and call signs authorized by corps. Normally, subordinate units of the division are permitted to use only their assigned operational frequencies. However, the brigade commander may authorize a changeover to spare frequencies when interference occurs. The division radio officer is notified immediately about the interference problem and the changeover.

**NOTE:** When an automated CEOI assigning frequencies and call signs is used, the division radio officer is responsible only for its distribution and coordinating its implementation. In cases of interference, he forwards reports of changes to alternate frequencies and call signs to the corps C-E section.

d. Coordinating with the radio officers of the other divisions to establish common frequency usage and to solve interference problems.

### **5-19. The Automated CEOI**

The National Security Agency (NSA) prepares, publishes, and forwards the automated CEOI to theater for further, controlled distribution with the theater. The automated CEOI is based on input frequency requirements and unit lists within the theater which are submitted to NSA (or gathered by ASA teams). A computer is used to assign both frequencies and call signs on a randomly accessed, nonpredictable basis. This precludes duplication of call signs and minimizes the interference of frequencies. The CEOI includes alternate frequencies for use in isolated cases of interference problems.

**a. Call Signs.** The automated CEOI includes call signs which are assigned to a unit, not to a net. Each call sign is a letter-number-letter (LNL) combination that is pronounced phonetically; e.g., A1B is alpha one bravo. Two-word call signs (as described in ACP 119) will no longer be used. The system of randomly assigned, daily changing suffixes (similar to the telephone directory arrangement) is used to expand the basic LNL call sign.

**b. Changes to the CEOI.** The C-E officers at division, corps, and theater army are responsible for the management of call signs and other aspects of the automated CEOI. Each C-E officer distributes CEOI material to the subordinate using units and is responsible for its proper use. Routine changes to the CEOI, such as additions, deletion of authorized frequencies, changes in organizations, etc., may be forwarded direct to NSA or through the ASA support teams.

## **5-20. Contingency Planning**

**a. Contingency planning** is performed continually at all echelons to provide direction in anticipation of force redeployment or specific emergency situations that could disrupt or threaten the continuity of communications networks. Its purpose is to insure the rapid establishment, restoration, or rerouting of both user and C-EMS communications. Contingency planning should be included in the planning and design of a communications system or installation to insure its reliability; or, may be in response to planning requirements originated within the C-EMS structure to cover specific situations.

**b. Communications reliability** is the first consideration in all planning. To insure reliability, the C-E planner must provide a communications system with alternate means; train personnel to operate equipment properly during situations of stress and emergency; include in SOP's the requirement for dispersion and protection of critical communications facilities; and provide supply and maintenance support to reduce circuit outages to an absolute minimum.

**c. The C-E officer** is responsible for C-E contingency planning within a major command and provides planning guidance to subordinate signal units. The contingency plans of senior supporting signal units should be reviewed and approved by the C-E officer of the major command. Normally, the C-E officer of the major command will issue a planning directive specifying the conditions that constitute the contingency requirements. Typically, the conditions are damage resulting from enemy action, weather, a disruption due to fire, equipment failure, or other catastrophe. The guidance should also specify the degree of damage to be considered, such as loss or damage to a major equipment item, an entire node, or an extension link. Planning constraints are also provided regarding available resources and restoration priorities. Based on the guidance in the planning directive, appropriate echelons within the C-EMS structure will prepare contingency plans.

**d. The major command contingency plan** will generate the development of implementing plans by subordinate units. Specified restoral actions may include patching and rerouting, institution of restriction measures, or replacement of major equipment configurations and operating teams. Included in the contingency planning process is the requirement to dry-run the plan to determine its effectiveness and to provide a basis for required modifications.

**e. Contingency planning** must include a COMSEC element. Emergency plans must be prepared for use in case of natural disaster, enemy attack, and/or civil riot or uprising. Refer to AR's 380-40 and 380-41 for additional information.



## **5-21. Recording User Locations**

**a.** Information regarding the location of users of communications facilities is essential both for accurate planning and engineering of communications systems and for communications support by communications nodes. Planners must be aware of all locations of supported users to include allies and other US forces, as well as Army units. User locations become more defined and detailed as an operation progresses and as information becomes available about current and future command post locations, to include main, TAC, etc.

**b.** C-EMS elements and the user have joint responsibility in recording user location: the user must report his current and planned locations; and, the C-EMS elements must keep all units involved in supporting the user aware of the locations.

(1) The C-E section of each major command maintains records of user locations and provides information to senior signal units concerning future unit arrivals, departures, and movements as soon as the information becomes available.

(2) The CSCE's maintain information on locations of major command headquarters, separate command headquarters, brigade, and group headquarters supported by the communications system for which they are responsible.

(3) The CNCE's provide the locations of supported units by reporting unit arrivals or departures to controlling CSCE's using telecommunications service orders (TSO) or special communications authorization requests (SCAR) if communications service for new units has not been planned.

## **5-22. Security**

**a.** Both communications security (COMSEC) and system security are responsibilities of the commanders at all echelons. And although the C-E officer at each echelon acts for the commander in all matters pertaining to COMSEC and system security, security is everybody's business—from the highest commander to the lowest ranking enlisted person.

**b.** COMSEC is the protection that results from all measures designed to deny unauthorized persons any information of value which might be derived from the possession and study of telecommunications; or, to mislead unauthorized persons in their interpretation of the results of such possession and study. COMSEC includes:

(1) Cryptosecurity.

(2) Transmission security.

(3) Emission security.

(4) Physical security (of communications security materials and information).

(5) The security of unclassified material which, if pieced together with other material, might reveal classified intelligence.

(6) Accounting for COMSEC material and CEOI items, to include maintaining records and data on COMSEC practices essential to maintaining required standards of system security. Data processing methods should be used for accounting purposes.

**c.** System security must be considered during the planning, engineering, and control of the communications system. It is especially important in laying out the network and disseminating information. Security is also a

prime consideration in assigning frequencies and call signs (implemented by automated CEOI). System security includes:

- (1) Specifying physical security requirements.
- (2) Insuring availability of appropriate COMSEC material (ciphers, codes, cryptographic equipment, key lists, key cards, etc.).
- (3) Specifying procedures for insuring security, such as the maximum time periods between call sign, frequency, and cryptographic key changes (if not specified in the automated CEOI).
- (4) Preparing policies to implement AR 380-40 and AR 380-41 regarding the accounting for and safeguarding of COMSEC material.
- (5) Analyzing traffic to insure proper use of COMSEC capabilities.
- (6) Engineering the communications system to insure communication security (for example, meeting "TEMPEST" and other standards).
- (7) Insuring the reporting of COMSEC violations and of practices dangerous to security.

d. At the national level, the US Communications Security Board (USCSB) establishes national COMSEC policy which is amplified and promulgated by Army regulations (AR's). C-EMS system security measures are established under the national COMSEC policy; they also comply with directives promulgated by the Department of Defense (DOD).

e. The theater commander is responsible for the enforcement of COMSEC in the command. He is assisted and advised by the theater C-E officer. Within the theater, C-E officers of major commands and commanders of signal units are responsible for integrating COMSEC policies and procedures into all C-EMS functions, from planning through implementation.

### **5-23. Messenger Service**

a. Messenger service is the most secure means of communications available to all units. It is the most effective method for the transmission and delivery of bulky items. Although it is flexible and reliable, its speed depends on the mode of travel (foot, motor, or air), tactical situation, and terrain trafficability. Messenger service complements the multichannel command and area systems. It is used to insure continuing communications and to provide service not available or permitted over multichannel links.

b. Messenger service may be either scheduled or special.

(1) Scheduled service is used when unit locations are stable and when unit volume is large.

(2) Special messengers are used when either more rapid service or special handling is required.

c. The commander of the senior signal unit is responsible for operating a messenger service for the major commands in both the command and area systems (table 5-4). The C-E section of each major command establishes the requirements for messenger service and publishes the routes, schedules, and message relay points (in the C-E annex).

d. The commander of each communications node is responsible for the direct supervision of the messenger service provided by the node, for

## Typical Messenger Service Responsibilities

Type Units	Typical Messenger Mission
<b>Theater Army:</b>	
<input type="checkbox"/> Messenger Co	Operates message relay stations, provides service between message relay station and relay points in COMMZ, TA area nodes, and subordinate command nodes. Air message service as needed.
Comm Cen Op Co	From each platoon(s) to supported units and message relay points.
Lge HQ Op Co	Local messenger service with HQ complex, supported units in assigned area of responsibility and message relay point.
Med HQ Op Co	Same as large headquarters operation company.
Small HQ Op Co	Same as large headquarters operation company.
<b>Corps:</b>	
<input type="checkbox"/> HHC, Comd Op Bn	Air messenger service from corps headquarters echelons to major subordinate units and area signal battalions. Motor messenger service for corps rear.
Telecom Cen Co	Messenger service from main to corresponding subordinate command headquarters echelon and units and to area nodes.
HHC, Corps Area Sig Bn	Service from battalion distribution point to area nodes and between battalions as designated by signal brigade CSCE.
<b>Division:</b>	
<input type="checkbox"/> Comd Op Co	Messenger service to major subordinate elements of division (air service from division aviation battalion).
Fwd Comm Co	Each forward signal center platoon (3) provides special messenger service within area of responsibility.

**Note:** For additional information on messenger scheduling and routing, refer to FM 24-16.

**Table 5-4. Typical Messenger Service Responsibilities**

coordination of schedules to meet location conditions, and for providing special messenger service.

### 5-24. Directory Service

**a.** Directory service is the preparation and distribution of telephone directories for and to all users of the tactical telephone system. The directories contain information concerning use of the directories and of the automatic telephone system. They include the assignment of telephone switchboard designation names and subscriber telephone numbers.

**b.** The preparation and updating of directories are currently performed manually. When facilities become available, these actions will be performed by automatic data processing. The distribution of directories is usually one echelon up, two echelons down, and to adjacent echelons.

c. A master directory (table 5-5) is prepared, published, and distributed by the C-E section of the TCC(A). It provides users with a basic understanding of the tactical telephone system (automatic or manual) and instructions on how to use the system.

d. The regional/unit directory is an extract from and an extension of the master directory. It is prepared, published, and distributed by the C-E section of major commands below theater.

### Master Directory Format

<u>Item No</u>	<u>Item</u>	<u>Location</u>
1	Title	Front cover
2	Classification Warning	Front cover
3	Emergency Numbers	Inside front cover
4	Index	First page
5	General System Description <ul style="list-style-type: none"> <li>a. Introduction to Automatic Function</li> <li>b. Extent of the Automatic System</li> <li>c. Telephone Addressing Scheme</li> </ul>	
6	Operating Instructions <ul style="list-style-type: none"> <li>a. Local Calls</li> <li>b. PR-SL Zoning Chart</li> <li>c. Long Distance Calls</li> <li>d. Information Assistance</li> <li>e. Special Capabilities</li> </ul>	
7	Standard & Fixed Telephone Address Lists	
8	Telephone Installation/Repair/Complaints	
9	Notes	Last pages
10	Phonetic Alphabet	Inside back cover
11	Precedence System	Back cover

**Notes:**

1. Items 1 through 4 are standard requirements for either manual or automatic systems. Item 5 contains a brief description of the automatic telephone system and of the telephone addressing (numbering) scheme. It briefly describes the function, capabilities, and extent of the automatic system. It references FM 24-22 and FM 24-26 (with titles) for further detail.

2. Item 6 contains information in layman's terms to instruct the subscriber in using the telephone system. There are specific instructions pertinent to the automatic system, to include use of precedence, five-party conference, nine-party preprogramed conference, call forwarding, operator recall, and other special features unique to the automatic switch. Subscribers will be urged to study this section prior to using the automatic telephone system.

3. Item 7 contains standard telephone numbers for units and subscribers. These numbers are controlled by TCC(A) and include address lists (PR-SL's) of units throughout the theater.

4. Included also will be the master lists of the Fixed Directory Unit List (FDUL) and Fixed Directory Subscriber List (FDSL).

5. Item 8 lists instructions concerning telephone installation and repair and where to register complaints regarding service, etc.

6. Both master and regional/unit directories should include a PR-SL zoning chart for the theater of operations subject to classification restrictions. This will facilitate direct distance dialing throughout the automatic system by all users.

**Table 5-5. Master Directory Format**

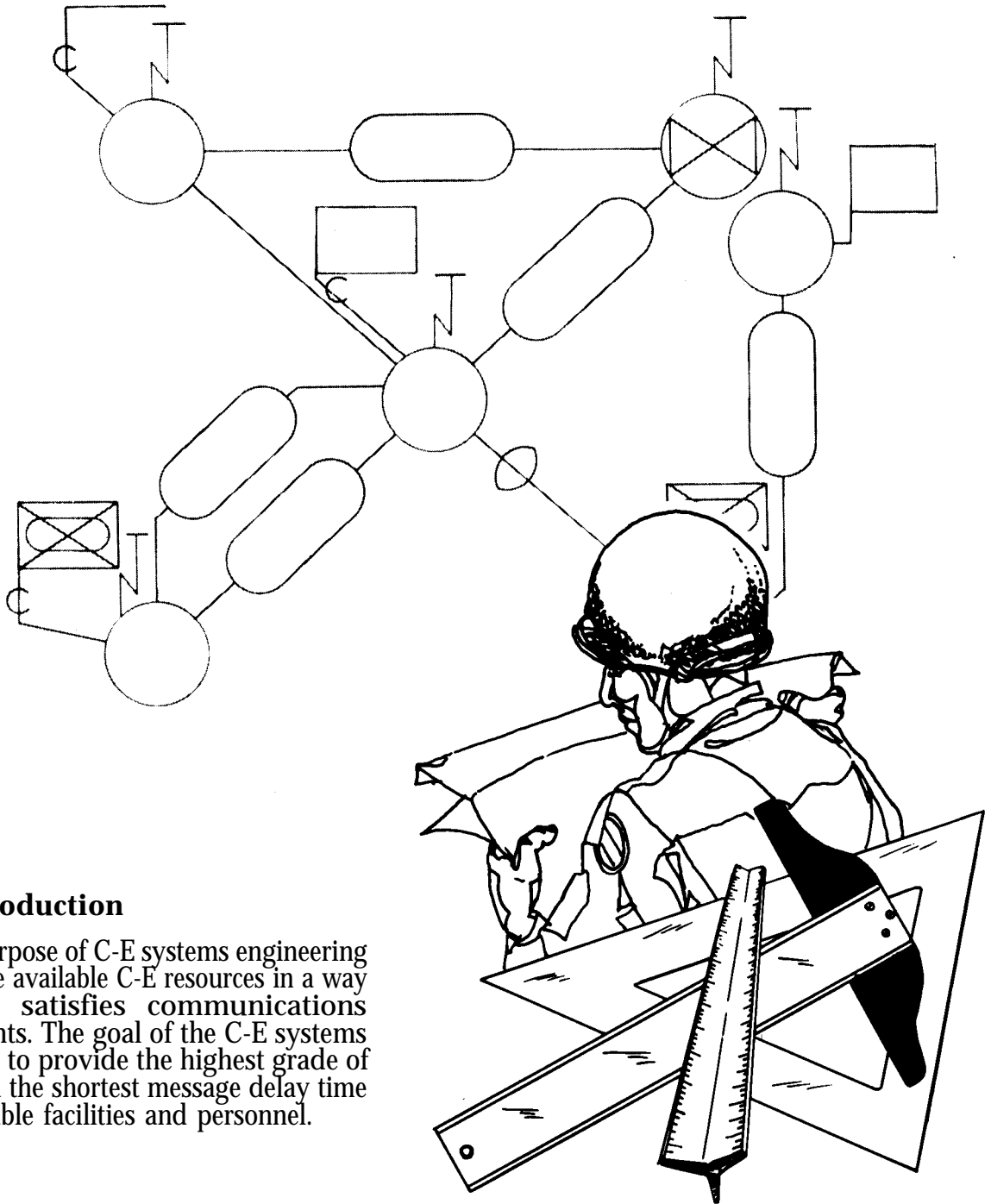

## 6-1. Introduction

The purpose of C-E systems engineering is to use the available C-E resources in a way that best satisfies communications requirements. The goal of the C-E systems engineer is to provide the highest grade of service and the shortest message delay time with available facilities and personnel.

## Sequence of Actions in Network Layout—Corps Area System

TACCOM and Corps CSPE	Signal HQ Staff	Signal Bde Staff & CSCE	CNCE
1. Review concept of operation as presented by Signal Officer			
2. Analyze possible network layouts			
3. Prepare typical network layouts with alternatives for each phase of operation			
4. Provide engineering advice to Signal Officer and other staff sections to influence estimates and planning	● Coordinate on engineering matters		
5. Analyze initial user locations	● Provide user location & requirements data		
6. Analyze gross user requirements			
7. Analyze enemy, terrain & weather			
8. Analyze hill top data	● Provide hill top data		
9. Analyze area center capability	● Provide organization status information		
10. Analyze future Area Center Requirements			
11. Establish tentative location of major CPs and Area Centers			
12. Perform reconnaissance (map or ground)	● Perform reconnaissance as required by Sig Staff		
13. Adjust Area Center Locations			
14. Establish areas served by each Area Center	● Coordinate on area assignments		
15. Analyze user requirements in detail <ul style="list-style-type: none"> <li>a. Dedicated circuits</li> <li>b. Trunk circuit utilization</li> </ul>			

**Table 6-1.** Sequence of Actions in Network Layout—Corps Area System

TACCOM and Corps CSPE	Signal HQ Staff	Signal Bde Staff & CSCE	CNCE
16. Establish connectivity of nodes	● Coordinate on network connectivity		
17. Establish points of interface with other communication systems			
18. Establish gross circuit requirements for each multichannel link			
20. Select transmission means	● Provide equipment status information.		
21. Select radio terminal and relay locations	● Coordinate on radio locations		
22. Determine gross extension system requirements	● Review Network Layout Development ● Review availability of resources		
23. Review Signal Area Bn nodal responsibilities	● Establish Signal Area Bn nodal responsibilities	● Review Network Layout Development	
		● Review availability of resources	
24. Review Area Center assignments		● Establish Area Center responsibilities	● Analyze user locations
		● Assist Area Companies in laying out extension system	● Perform Reconnaissance
			● Analyze user requirements
			● Determine extension system configuration
25. Present proposed Network Layout to Signal Officer			
26. Adjust Network Layout as directed by Signal Officer	● Adjust Signal Area Bn nodal responsibilities as required	● Adjust Area Center responsibilities as required	● Adjust extension system layout as required
27. Issue Network Layout Information			

## **6-2. Network Layout**

a. The C-E systems engineer prepares the network layout which is a schematic diagram of the multichannel communications system showing the nodal and interconnecting link configuration. The multichannel network layout reflects the commander's concept of future operations. It provides the basic guidance for engineering the command and area multichannel communications systems and for preparing circuit routing lists, and traffic and radio diagrams. Before an operation begins, the network layout is issued as a planning document to the supporting signal organizations and to higher, adjacent, and subordinate major commands.

b. The accuracy of the network layout depends on an extensive and current data base which should include the following:

- (1) User locations and requirements.
- (2) Available C-E resources.
- (3) Current status of existing networks.
- (4) Terrain conditions.
- (5) All available data on the enemy.

c. An extensive and reliable database, constantly being updated, is a must for developing the network layout, traffic, and circuit and systems diagrams. The C-E section of each major command, with planning and engineering assistance from the senior signal units, performs the network layout for the command. The elements involved and the logical sequence of actions in laying out a corps area system network are summarized in table 6-1.

## **6-3. Traffic Engineering**

Traffic engineering is the process of determining the anticipated traffic flow in a new multichannel system and the best distribution of C-E resources to accommodate a traffic routing plan that will handle the flow. Traffic engineering continues after the system is operational by analyzing the actual traffic flow to determine problem areas and deficiencies and taking corrective actions. It may sound simple but traffic engineering has its own peculiar complexities and must be performed systematically as described below and summarized in figure 6-1.

a. Determine Requirements. The data base and the network layout provide the basic information required for traffic engineering. Determinable factors that affect the traffic flow plan are user requirements for teletypewriter, data, and telephone services. These factors must be related to the speed and grade of service objectives to determine the needs for dedicated and switched circuits. Remember that the initial design of the network is influenced by the busy-hour, rush-period loads. At times, the traffic offered to the network (system) may reach peaks above that for which it is engineered. To cope with this imbalance between the offered load and available facilities, restrictive measures may be required (and planned for) during high traffic periods and when portions of the network are damaged.

b. Tandem Switching and Path Access Analysis.

- (1) After establishing circuit requirements, determine the desirability of tandem switching and the needs for alternate paths. The use of tandem switching reduces the overall circuit requirements but increases the telephone switch traffic loads.



PRIOR TO NETWORK INSTALLATION

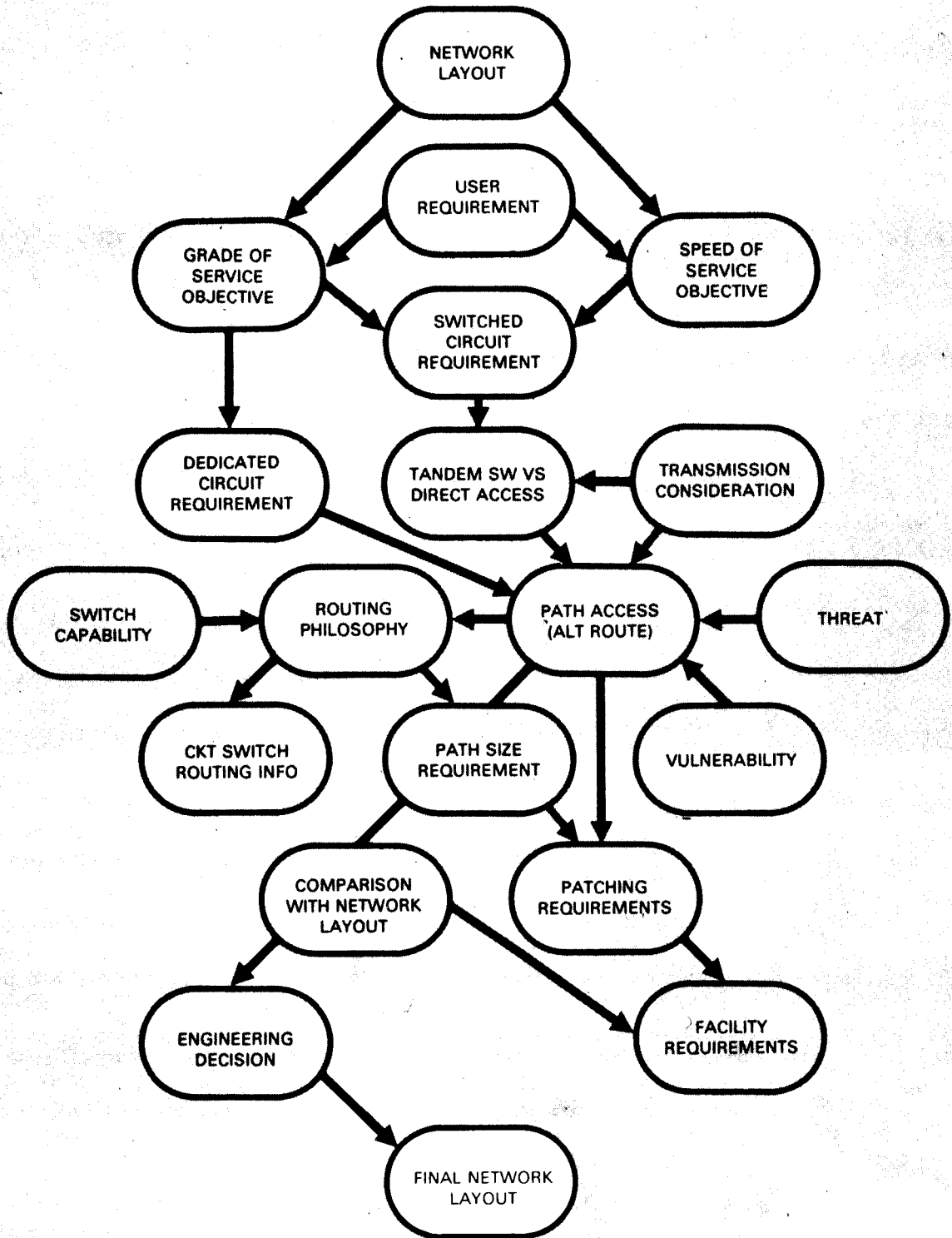
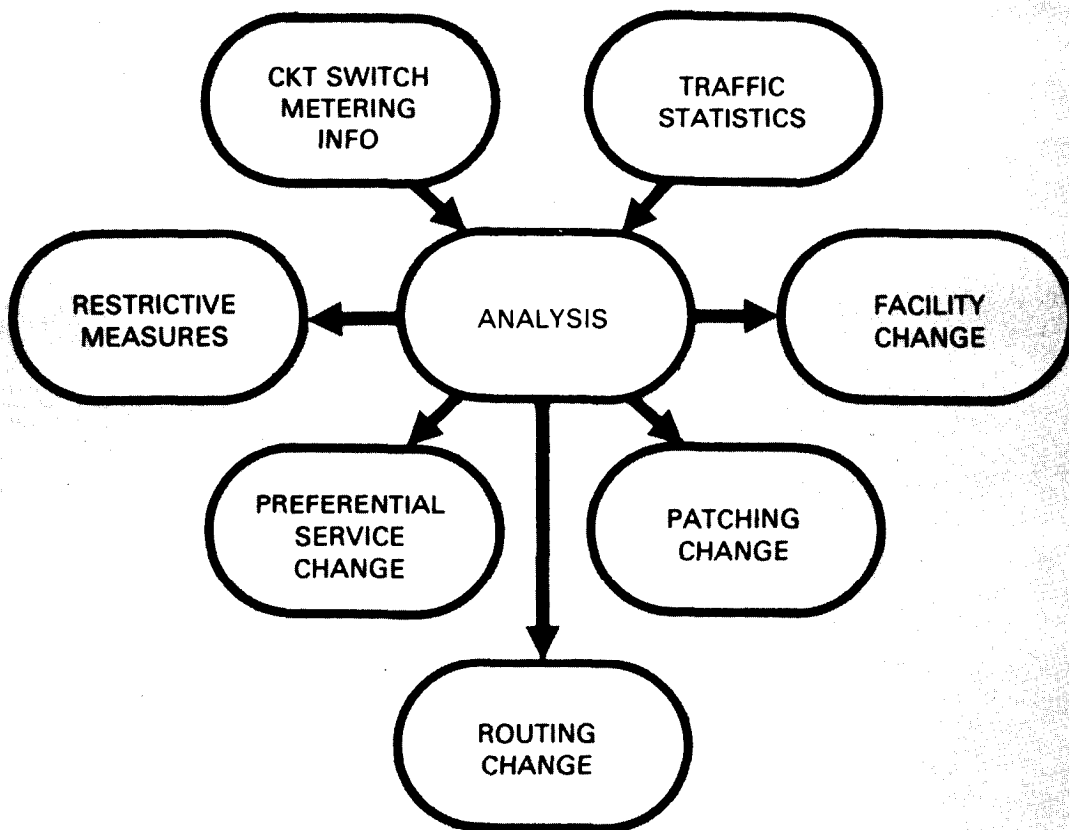

Figure 6-1. Traffic Engineering Procedures

## AFTER NETWORK INSTALLATION



**Figure 6-1. (Part Two) Traffic Engineering Procedures**

(2) Path access analysis is based on the estimated enemy threat and the vulnerability of the signal installation. The objective of the analysis is to determine the requirements for alternate routing means.

c. Routing Plan. Develop a routing plan after the tandem switching and path access requirements are established. In a new network (based on estimated or anticipated traffic data), the primary routes are usually selected on a least-cost or minimum circuit-miles basis. The capabilities of the switches for alternate routing and routing control (originating office or spill forward), and call shuttle hazards must also be considered. In addition, special routing requirements at communications interface points must be accommodated by the routing plan. For example, the routing may permit command system traffic to enter an area system but prohibit area system traffic from entering the command system.

d. Network Adjustments. After the routing plan is devised, determine the path size requirements and develop instructions for the routing program of each switch. Next, determine the patching requirements and compare the path size requirements with the available facilities as designated in the network layout. Based on the comparison, make appropriate adjustments in the facilities requirements and modify the network layout accordingly.

e. Traffic Analysis. After a network is installed and operational, the traffic engineer continually analyzes its operation to determine problem areas and

areas for improvement of the service. The analysis is based on input information obtained from metering devices that measure the various kinds of traffic in the network and permit a qualitative and quantitative view of its operation. Most of the required information is provided in the Traffic Status Report (app C). Metering at tactical automatic switches (TAS) is described in an appendix of FM 24-26. The main objectives of traffic analysis are to:

- (1) Change network facilities and systems, if necessary, to accommodate required traffic. This may lead to an expansion or curtailment of certain facilities.
- (2) Decide if and how the routing plan must be changed.

#### **6-4. Traffic Engineering Responsibilities**

Traffic engineering for multichannel communications supporting the Army in the field is performed primarily at the theater army and corps levels.

a. Traffic engineering is performed by the:

- (1) TCC(A) CSPE for theater army command and area communications systems.
- (2) Corps signal brigade CSCE for command and area communications systems in the combat zone down to the division level.
- (3) Division signal battalion CSCE for the division communications systems.

b. When tactical automatic switches are employed:

- (1) The TCC(A) and signal brigade CSCE's coordinate the automatic switch data base changes for the COMMZ and combat area.
- (2) In the combat zone, the database changes for automatic stitches at corps nodes and division main will be coordinated by the corps signal brigade CSCE.
- (3) The corps signal brigade CSCE must include the automatic switches in the combat area in its traffic engineering. It will receive traffic status reports for the switches from the corps and the division signal battalion.

#### **6-5. Telephone Traffic Engineering**

a. Manual and Dial Central Offices. The important aspects of traffic engineering for manual and dial central offices are trunk group planning (fig 6-2) and determining operator position requirements. The procedures for obtaining and using traffic data for engineering networks with manual switching controls are covered in TM 11-486-2. Although TM 11-486-2 establishes traffic engineering standards for fixed communications networks, the standards may also be used as guides for tactical systems.

b. Tactical Automatic Switches (TAS). During the transition from manual to fully automated telephone networks, the problems of integrating the systems involved (interface requirements, PR-SL assignments, routing controls, etc.) generate a need for flexible management procedures. For example, the TAS is an important factor in systems control because of its ability to provide preferential services and implement restrictive measures. Also, metered traffic data should flow directly from the TAS's to controlling CNCE(M)'s with information printouts going to appropriate CSCE's. The point is that managers must be thoroughly familiar with the operation and management of both manual and automated systems.

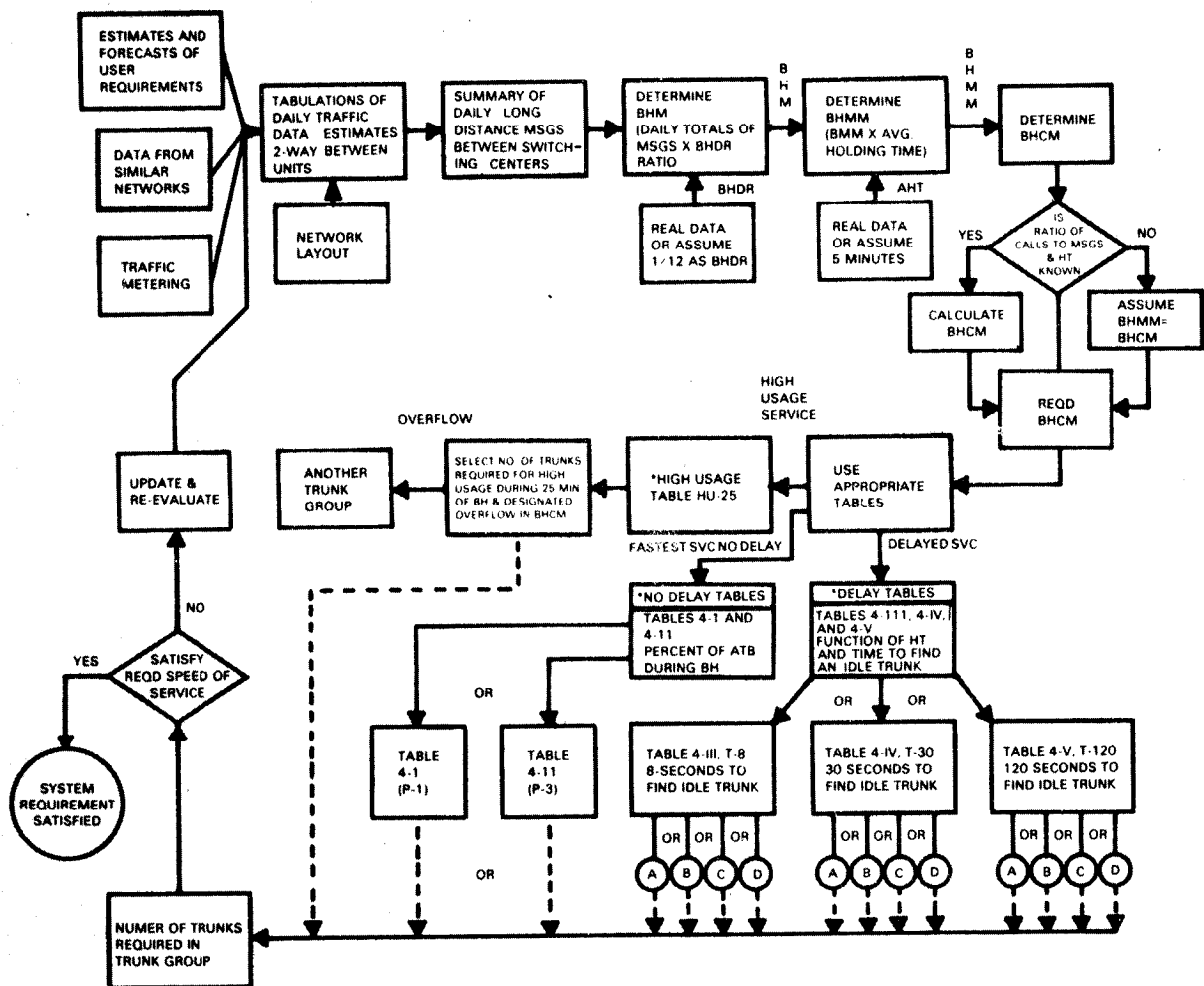

**Notes:**

\*Reference to Tables in Part Two of TM-11-486-2  
 BHDR = Busy Hour to Day Ratio  
 BHF = Busy Hour Messages

BHMM = Busy Hour Message Minutes  
 AHT = Average Holding Time  
 BHCM = Busy Hour Call Minutes  
 HT = Holding Time

Holding Times  
 A 6 Minutes  
 B 6-7.5 Minutes  
 C 7.5-9 Minutes  
 D 9 Minutes

**Figure 6-2. Traffic Engineering-Telephone Networks With Manual Switching**

## 6-6. Teletypewriter/Data Traffic Engineering

a. Teletypewriter Traffic. The teletypewriter trunking plan must be designed to accommodate the required speed of service and traffic volume. At the same time, the number of message switching processes between teletypewriter facilities should be kept to a minimum. Since routine and deferred teletypewriter traffic can be delayed, the load curve (amount of traffic, by precedence, transmitted throughout the day) and the time required to clear the traffic (speed of service) must be carefully considered in planning. The traffic engineer should plan to use the periods of minimum traffic to accommodate the low precedence traffic that is normally delayed during busy hours. This procedure permits channels to be selected on an average-hour basis rather than a peak period or busy hour basis. Procedures for developing the teletypewriter trunking plan (fig 6-3) are covered in TM 11-486-2.

## REQUIREMENTS & ESTIMATES

\*Total No. of Daily Messages by Speed, Precedence, Users

Daily Load Curve  
TTY Circuit & Traffic Diag.

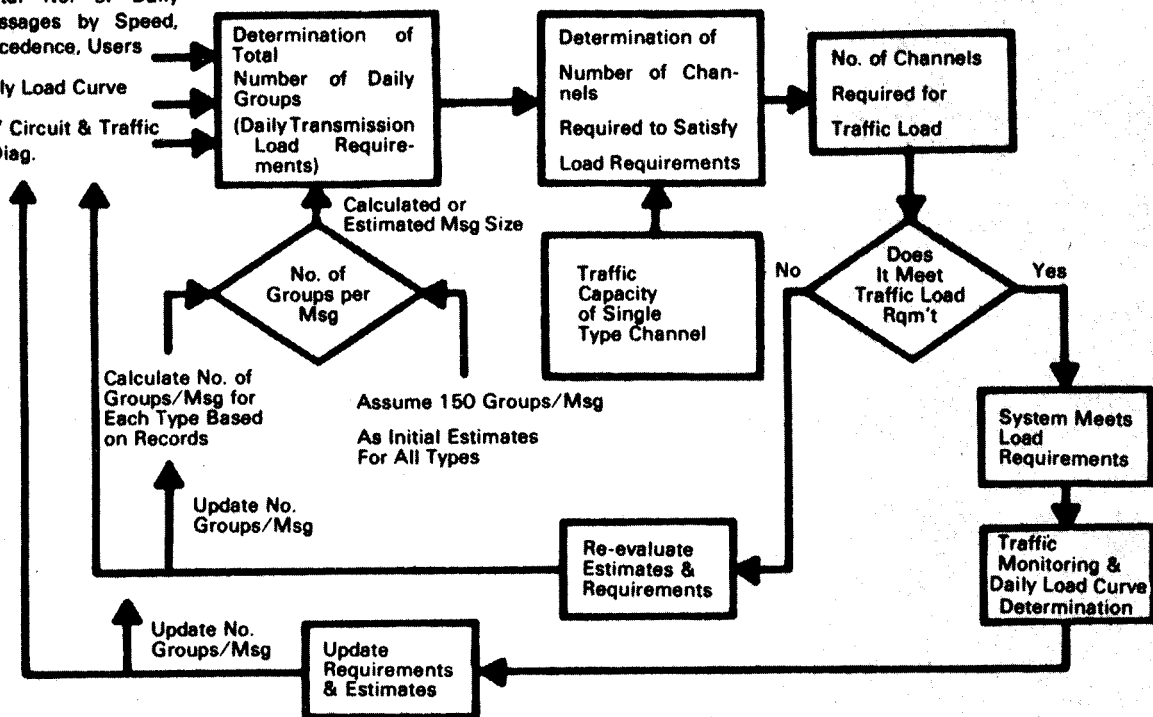

### \*NOTE

The Number of Channels Required for Estimated Traffic Load is Determined from Tables 10-1 through 10-IX (TM-11-486-2) and The Following Factors:

- Type of Equipment - Keyboard, Tape, etc.
- Speed of Equipment - Words per Minute
- Outage Factors - Circuit Trouble, Maintenance, etc.
- Efficiency of Personnel
- Type of Operation - Manual, Automatic, Semi-Automatic
- Type of Channel - Full-Duplex, Half-Duplex
- Speed of Service Desired
- Load Curve
- Precedence Percentage by the Hour

**Figure 6-3. Summary of TTY Traffic Engineering Procedures**

### Circuit Routing List

CH	CIRCUIT	PR	TY	FROM	SYS 1	SYS 2	SYS 3	SYS 4	CHANNEL SETTING	TO
01	421J161	3C	CU	9221	21J1PAA-01				4W OFF/4W OFF	8765
02	10123ZZ	3C	SU	EW	0121PAC-02	21J1PAA-02	23J1CAA-01		4W OFF/4W OFF	EW
03	622J133	4B	SU	S3	2122PAC-01	21J1PAA-03			4W OFF/2W OFF	G3
04	G01J14C	3C	TT	TCC	0121PAA-01	21J1PAA-04			4W OFF/2W ON	MR
05	322J121	4A	CU	9222	2122PAC-02	21J1PAA-05			4W OFF/4W OFF	8765
06	B22J18E	3A	SC	Data	2122PAC-06	21J1PAA-06			4W OFF/4W OFF	TADS
07	421J162	3C	CU	9221	21J1PAA-07				4W OFF/4W OFF	8765
08	G21J11C	3B	TT	MR	21J1PAA-08				4W OFF/4W OFF	MR
09	82123GG	4A	LL	9221	21J1PAA-09	23J1CAA-02			4W OFF/4W OFF	SASP
10	102J1HH	3C	SU	CBRE	0102PAA-01	0122MAA-01	2122PAC-08	21J1PAA-10	4W OFF/2W ON	CBRE
11										
12	121J1CC	1A	SU	CNCE	21J1PA-12				2W ON/2W ON	CNCE

System 21J1PAA  
Priority 3A  
Page 14

**Table 6-2. Circuit Routing List**

**b. Data Traffic.** Planning for data trunks is similar to planning for teletypewriter trunks. Data trunks, however, are more critical in that they require wider bandwidth and higher quality circuits.

## **6-7. The Circuit Routing List/Bulletin**

A circuit routing list (table 6-2) provides detailed information required for interconnecting system components. It also provides the patching arrangements required for telephone, teletypewriter, and data circuits in a multichannel communications network. A circuit routing bulletin provides change information to an existing circuit routing list. Changes may also be published as replacement pages to the circuit routing list using the format shown in table 6-2 and appendix C.

**a. Preparation.** The C-E staff prepares circuit routing lists and bulletins issued by divisions and higher echelons. The C-E officer at each echelon is the responsible individual. Above division level, the C-E section is assisted by systems engineering personnel of the senior signal unit supporting the echelon.

**b. Input Information.** Preparing a circuit routing list or bulletin requires a detailed knowledge of the status of all resources, as well as the decisions made in preparing the network layout and in traffic engineering. This information is maintained in the CSCE supporting the major command and is updated continuously as activation/deactivation reports are received from the CNCE(M)'s.

**c. Distribution.** The circuit routing list is distributed as a part of a technical directive to subordinate CSCE's and CNCE(M)'s for implementation. The technical directive is a basis for orders to operating teams for equipment installation, wire and cable installation, and patching at the appropriate CNCE(T)'s.

**d. Changes.** Changes to the circuit routing list may be directed by a CSCE or they may be the result of circuit actions at a node which has delegated authority to initiate changes. When circuit changes are implemented at a node, they are reported in telecommunications service orders and trouble reports. Changes to circuit routing lists are posted at each CSCE and CNCE(M) immediately after the changes are implemented.

## **6-8. Traffic Diagrams**

A traffic diagram is a schematic representation of traffic routing information. The purpose of a traffic diagram is to provide a simplified reference for determining trunk routing within the communications network. Separate diagrams are used for telephone (fig 6-4) and teletypewriter/data (fig 6-5) networks. Traffic diagrams are typical of circuits installed but do not prescribe the exact circuits installed in every system. The diagrams should show the traffic flow among all elements of the major command and the principal routes to other networks and installations.

**a. Preparation.** Each major command CSCE is responsible for preparing traffic diagrams of its communications networks. The corps CSCE prepares consolidated traffic diagrams for the combat zone. The chief operator at each switch should prepare simplified diagrams required by the operators and attendants from the diagram and information provided by the CSCE.

**b. Input Information.** The network layout is the principal source of information for developing traffic diagrams. In an operational network, information for improvement and required changes (reflected in traffic diagrams) is derived from telecommunications service orders, trouble, and traffic status reports.

(EXAMPLE)  
**TELEPHONE TRAFFIC DIAGRAM**

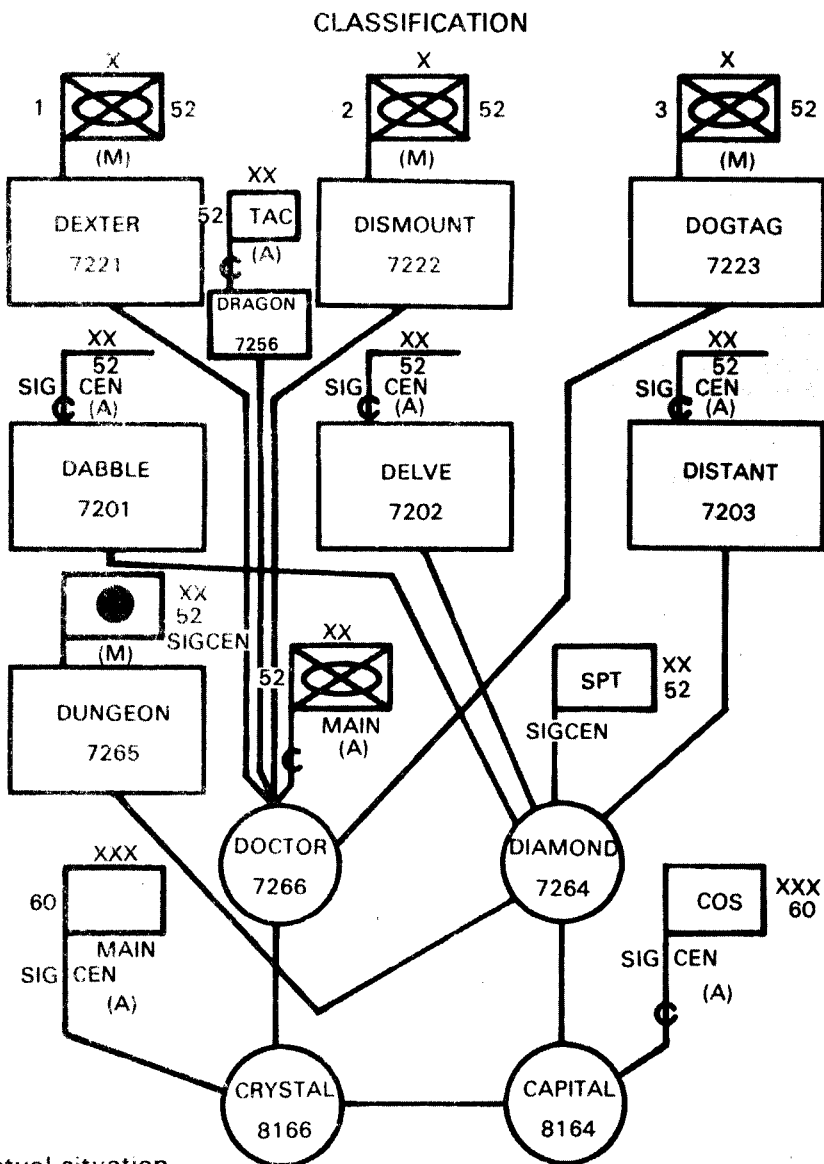

NOTE: In actual situation, may be desirable to include number of circuits (Number adjacent to line connecting centers) between centers.

M - Manual  
 A - Automatic

COPY \_\_\_\_\_ OF \_\_\_\_\_ COPIES  
 LOCATION \_\_\_\_\_  
 DATE \_\_\_\_\_ TIME \_\_\_\_\_

ACKNOWLEDGE:  
 POSITIVE  
 LTC.

ANNEX F, TELEPHONE TFC  
 DIAGRAM, TO OPORD 13,  
 152d SIG BN  
 REF: MAP 1:50, 000, MONSOON,  
 SAVAN, M2300  
 EFFECTIVE 231730 JAN 1976

CLASSIFICATION

OFFICIAL: \_\_\_\_\_  
 /s/ Action  
 ACTION  
 DISTRIBUTION: A

**Figure 6-4.** Example Telephone Traffic Diagram



(EXAMPLE)

# TELETYPEWRITER TRAFFIC DIAGRAM

## CLASSIFICATION

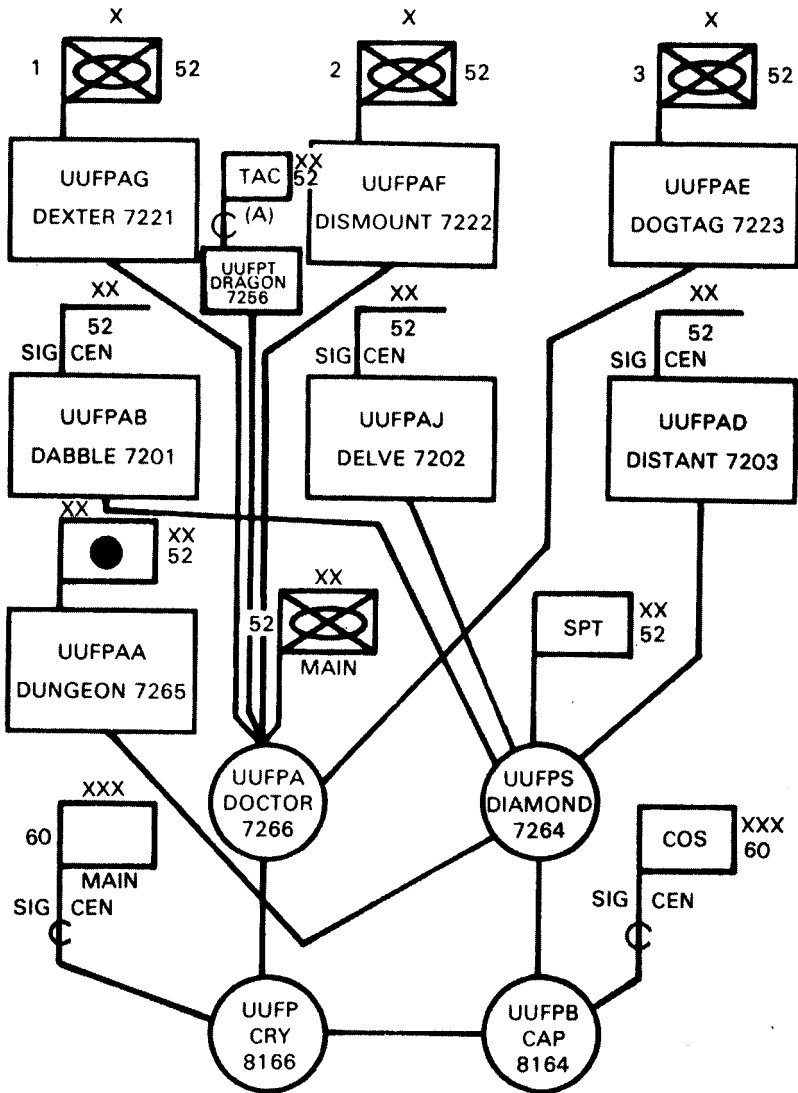

NOTE: In actual situation, it may be desirable to include number of circuits (number adjacent to line connecting centers) between centers.

COPY \_\_\_\_\_ OF \_\_\_\_\_ COPIES

LOCATION \_\_\_\_\_

DATE \_\_\_\_\_ TIME \_\_\_\_\_

ANNEX E, TELETYPEWRITER TRAFFIC DIAGRAM TO OPORD 13, 152d SIG BN.

CLASSIFICATION

OFFICIAL:

ACKNOWLEDGE:  
POSITIVE  
LTC.

/s/ Action  
ACTION  
DISTRIBUTION: A

Fig 6-5. Example Teletypewriter Traffic Diagram

**Example  
Telephone Routing Bulletin (Partial)**

**52D INFANTRY DIVISION (MECH)  
TELEPHONE ROUTE BULLETIN**

<b>UNIT AND COMMUNICATIONS DESIGNATOR</b>	<b>PRIMARY ROUTES WITH SWITCHBOARD DESIGNATION</b>	<b>ALTERNATE ROUTE WITH SWITCHBOARD DESIGNATION</b>
Engineer Battalion-DETONATE	DIAMOND	DOCTOR MAIN
HHC-DETONATE	DIAMOND	DOCTOR MAIN
Co A-DETONATE RED	DELVE	DEXTER
Co B-DETONATE WHITE	DELVE	DISMOUNT
Co C-DETONATE BLUE	DELVE	DOGTAG
Medical Battalion DENTIST	DIAMON	DOCTOR MAIN
HQ & Spt Co DENTIST	DIAMOND	DOCTOR MAIN
Co A DENTIST 55	DIAMOND	DOCTOR MAIN
Co B DENTIST 66	DIAMOND	DISMOUNT
Signal Battalion DEPENDABLE	DIAMOND	DOCTOR MAIN
HHQ DEPENDABLE	DIAMOND	DOCTOR MAIN
Co A DEPENDABLE A	DOCTOR MAIN	DIAMOND
Co B DEPENDABLE B	DIAMOND	DOCTOR MAIN
Co C DEPENDABLE C	DOCTOR MAIN	DIAMOND

**Table 6-3.** Telephone Routing Bulletin

c. Distribution. Traffic diagrams are published in C-E operations orders, the C-E annex of the command operation order, or in a technical directive issued by a CSCE. Simplified traffic diagrams are often published in telephone directories to assist subscribers in selecting call routes.

d. Changes. Changes to traffic diagrams are required when units and nodes displace, when systems interface and routing changes, and when traffic congestion occurs. The changes may be published as replacement pages or in a communications system document change order.

**Note:** Updating changes to traffic diagrams becomes essential as more semiautomatic switches are introduced into the division area. Automatic switches such as the SB-3614/TT (AN/TTC-41) require SL identifications when they are used in the division level system. Thus, SL's must be included on the traffic diagram to identify the switches. Fully manual switchboards do not require and are not assigned SL numbers unless they directly interface with a TAS (AN/TTC-38). Routing and PR-SL assignment in a TAS system are covered in FM 24-26.

## **6-9. Traffic Route Bulletin**

A traffic route bulletin (table 6-3) is an extract from circuit and traffic diagrams. It provides information on primary and alternate communications routes.

- a.** In manual systems, the traffic route bulletin presents a tabular list of the major unit headquarters and their subordinate commands served by other nodes of the communications network. The bulletin lists each unit, its communications designator or code name, and the primary and one or more alternate route(s) (designated by identifying intermediate nodes).
- b.** In TAS networks, the traffic route bulletin may be used to designate primary and alternate routes for the routing tables at each switch.

## **6-10. Line Route Map**

A line route map is used to specify and record the wire and cable routes in a communications system. It also pinpoints the locations of the facilities associated with the lines. The line route map is keyed to a topographic map(s) or map substitute and is usually prepared as an overlay (fig 6-6).

- a. Preparation.** The C-E section of each major command prepares a line route map based upon the command's wire and cable requirements.
- b. Input Information.** When a signal construction unit installs a wire or cable system, it records any deviations from the specified wire or cable routing on the line route map. This information, with reasons for any deviations, is collected by the wire chief at the node responsible for the installation. The wire chief reports the changes to the CNCE(M) which, in turn, reports them in a communications document change order to the controlling CSCE. The CSCE data base is then updated to reflect the actual routing. The CSCE data base should include—

- (1) Map coordinates of termination points.
- (2) Locations of test points, repeaters, and other installed facilities.
- (3) Locations of link/circuit/channel identifications.
- (4) Points of interface with other systems.
- (5) Cable type, size, and special characteristics.

(EXAMPLE)  
**LINE ROUTE MAP**  
 (CLASSIFICATION)

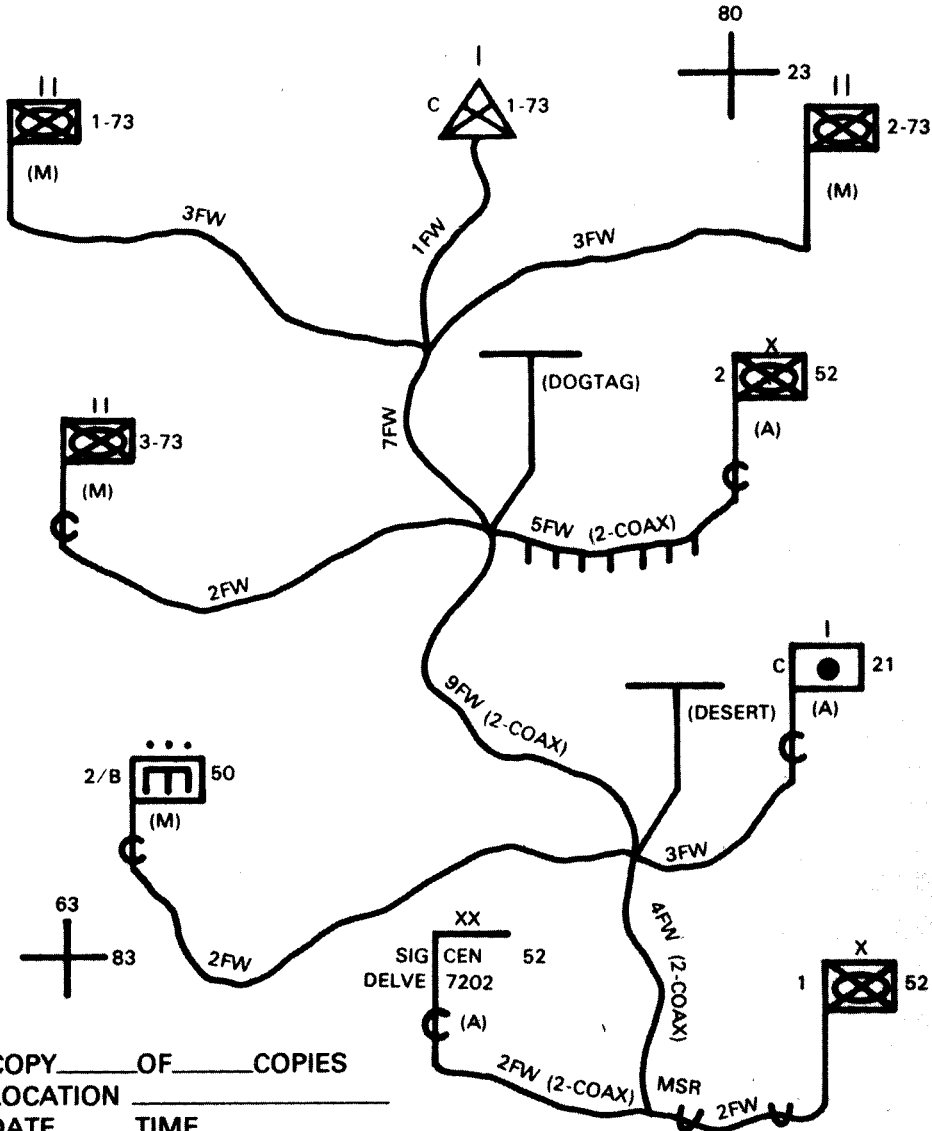

COPY \_\_\_\_\_ OF \_\_\_\_\_ COPIES  
 LOCATION \_\_\_\_\_  
 DATE \_\_\_\_\_ TIME \_\_\_\_\_  
 ANNEX A, LINE ROUTE MAP,  
 TO OPOD 13, 152d SIG BN.  
 EFFECTIVE 231730 JAN 1976  
 ACKNOWLEDGEMENT:  
 POSITIVE  
 COL

(CLASSIFICATION)

OFFICIAL:  
 /s/ ACTION  
 /t/ ACTION  
 DISTRIBUTION:

**Fig 6-6. Example Line Route Map**

c. Distribution. Line route maps are issued by the major command as a part of a plan, operation order, or as a part of a telecommunications service order. They are distributed to the supporting wire and cable construction units for implementation. CNCE(M)'s and controlling CSCE's should also receive and maintain copies of line route maps for all installed wire and cable systems within their areas of responsibility.

## 6-11. Multichannel Systems and Radio Net Diagrams

The multichannel systems and radio net diagrams contain the basic information necessary for the proper organization and operation of multichannel systems links and radio nets. The diagrams provide data required for frequency utilization and reduction of interference. They way also include information that specifies operating modes and conditions.

**a. Multichannel Systems Diagram (fig 6-7).** This diagram shows the multichannel system that supports a major command. Separate diagrams may be used for area and for command multichannel links.

(1) The diagrams include:

Locations and types of terminal radios, intermediate relays and operating frequencies, cable systems.

Antenna orientations (magnetic azimuths).

Site elevations.

Communications node locations at which multichannel groups are to be determined.

(2) Preparation. The C-E section of a major command and the senior signal unit prepare multichannel systems diagrams during the planning phase. The preparation procedure is shown in figure 6-8.

(3) Input Information. In preparing the multichannel systems diagram, the C-E section obtains information from the CSCE database concerning the network layout (equipment, operation, frequency, antenna azimuth data, etc.). The CSCE data base should be the most reliable source of information because it is continuously updated by change information from the CNCE(M)'s.

(4) Distribution. Normally, multichannel systems diagrams are issued as a part of the C-E annex to the command operations order.

(5) Changes. Changes to multichannel systems diagrams may be issued as replacement pages to the C-E annex or as bulletins in the communications system document change order format.

**b. Radio Net Diagrams (fig 6-9).** The types of radio nets for the army in the field are dictated by the tactical requirements for each using organization. Variations of the basic (standard) nets may be required because of unit missions, tactical resources, and available resources.

(1) Preparation (fig 6-10). The C-E staff of each major command prepares the radio net diagrams which are normally command oriented and supplement the multichannel systems. The senior signal unit and each organic subordinate unit prepare radio net diagrams which are forwarded to the command C-E section.

(2) Input Information. The senior signal unit obtains information from the CSCE data base on frequencies, call signs, and net composition. Frequencies and call signs are also listed in the CEOI.

(3) Distribution. Radio net diagrams are normally issued as a part of the C-E annex to the command operation order.

(4) Changes. Changes to radio net diagrams may be issued as replacement pages to the C-E annex or as bulletins in the communications system document change order format.

**EXAMPLE  
MULTICHANNEL SYSTEMS DIAGRAM**

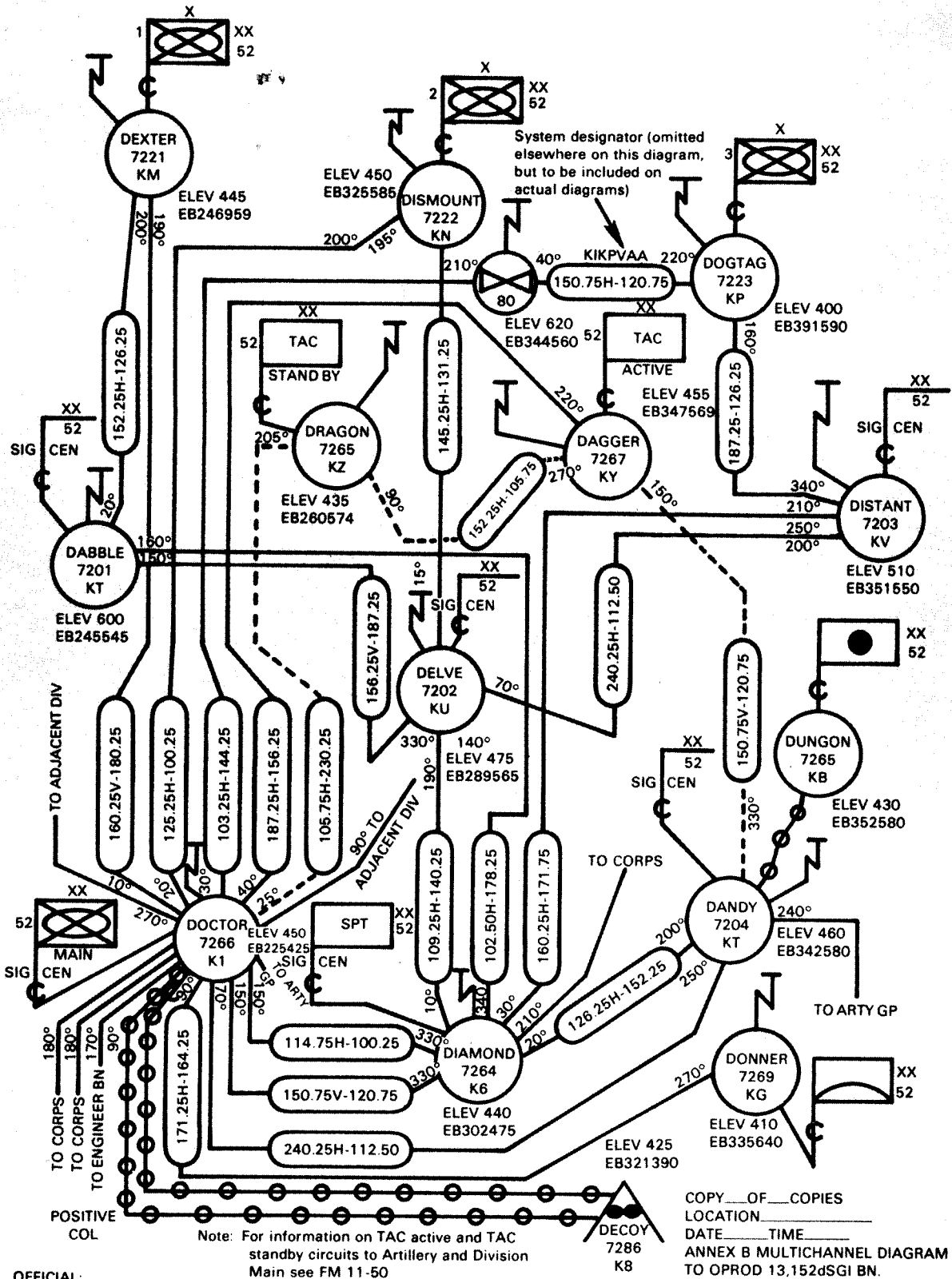

COPY \_\_\_ OF \_\_\_ COPIES  
 LOCATION \_\_\_\_\_  
 DATE \_\_\_\_\_ TIME \_\_\_\_\_  
 ANNEX B MULTICHANNEL DIAGRAM  
 TO OPROD 13,152dSGI BN.  
 REF: MAP 1:50,000 MONSOON  
 SAVAN, M2300  
 EFFECTIVE 231730 JAN 1976  
 DISTRIBUTION: A  
 ACKNOWLEDGEMENT:

OFFICIAL:  
 /s/ ACTION  
 ACTION  
 S3

**Figure 6-7. Example Multichannel Systems Diagram**

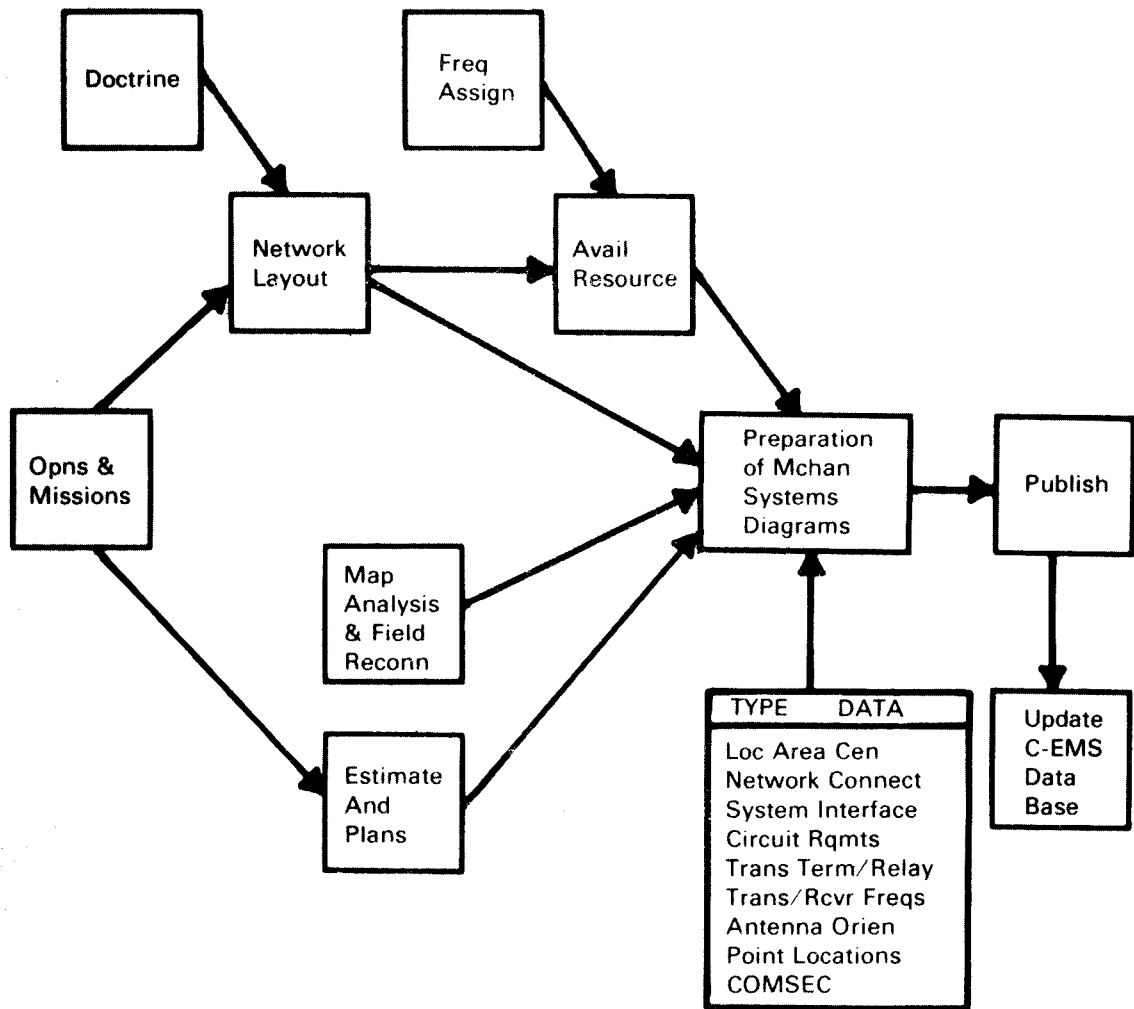

**Figure 6-8.** Procedures for Preparing Multichannel Systems Diagrams

(EXAMPLE)

# RADIO NET DIAGRAM (PARTIAL)

CLASSIFICATION

Copy \_\_\_\_\_ of \_\_\_\_\_ Cys  
152d Sig Bn  
Location  
Date - Time  
RCB5

Note: See CEOI for call signs and frequencies.

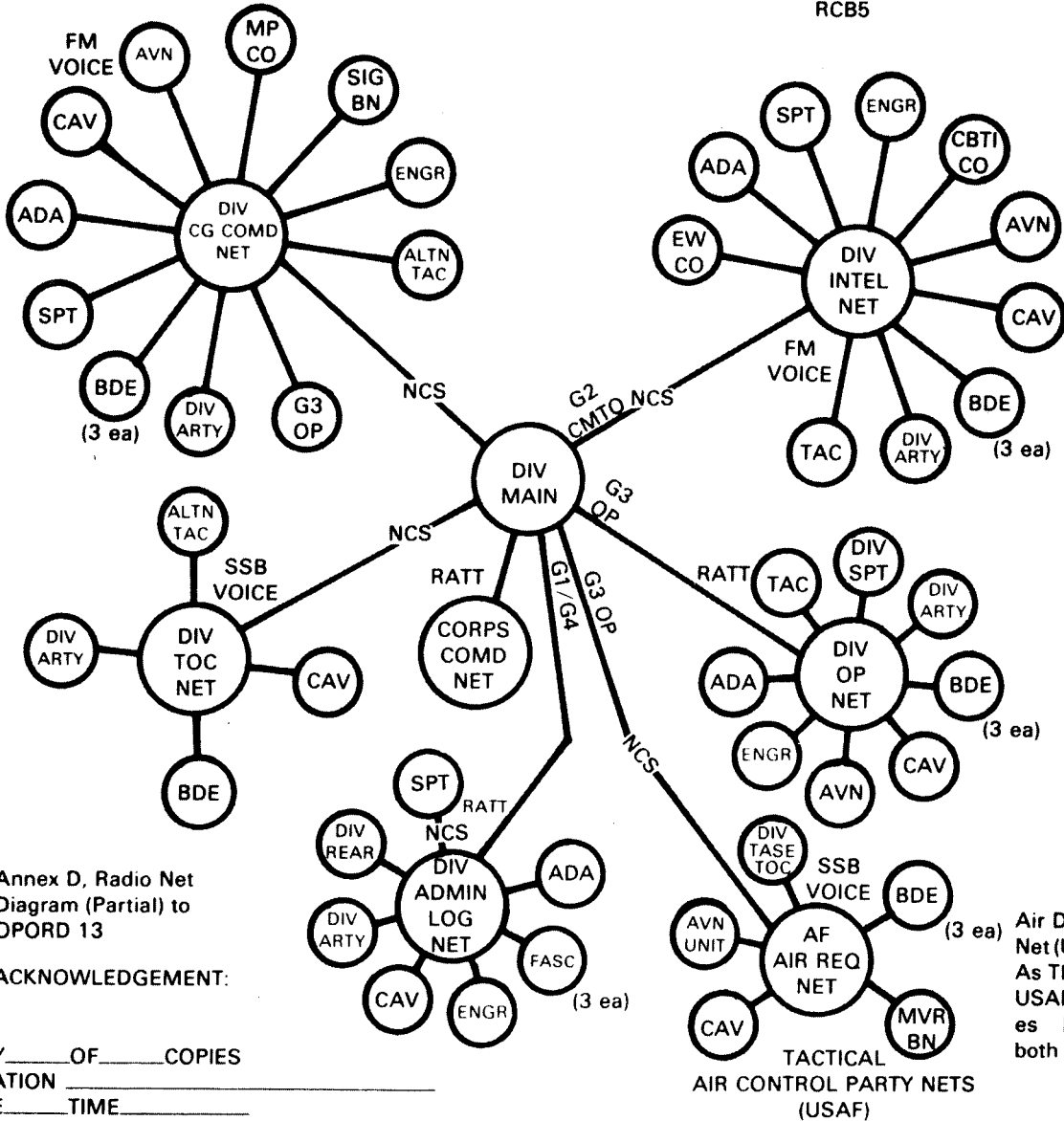

Annex D, Radio Net Diagram (Partial) to OPOD 13

ACKNOWLEDGEMENT:

COPY \_\_\_\_\_ OF \_\_\_\_\_ COPIES  
LOCATION \_\_\_\_\_  
DATE \_\_\_\_\_ TIME \_\_\_\_\_

ANNEX D, RADIO NET DIAGRAM, TO OPOD 13, 152d SIG BN  
REF: MAP 1:50, 000, MONSOON, SAVAN, M2300

ACKNOWLEDGEMENT:

DISTRIBUTION: A

POSITIVE COL

/s/ ACTION  
/t/ ACTION

NOTE: There are other nets not shown here:

- Div. Intel. Net (see note at Div. Op. Net)
- Div. Air Request Net
- Div. Air Direction Net (see note at Air Req. Net)
- Div. Weather Net

Air Direction Net (UHF) Same As This Net. USAF furnishes Equip. for both nets.

TACTICAL AIR CONTROL PARTY NETS (USAF)

CLASSIFICATION

Figure 6-9. Radio Net Diagram (Partial)



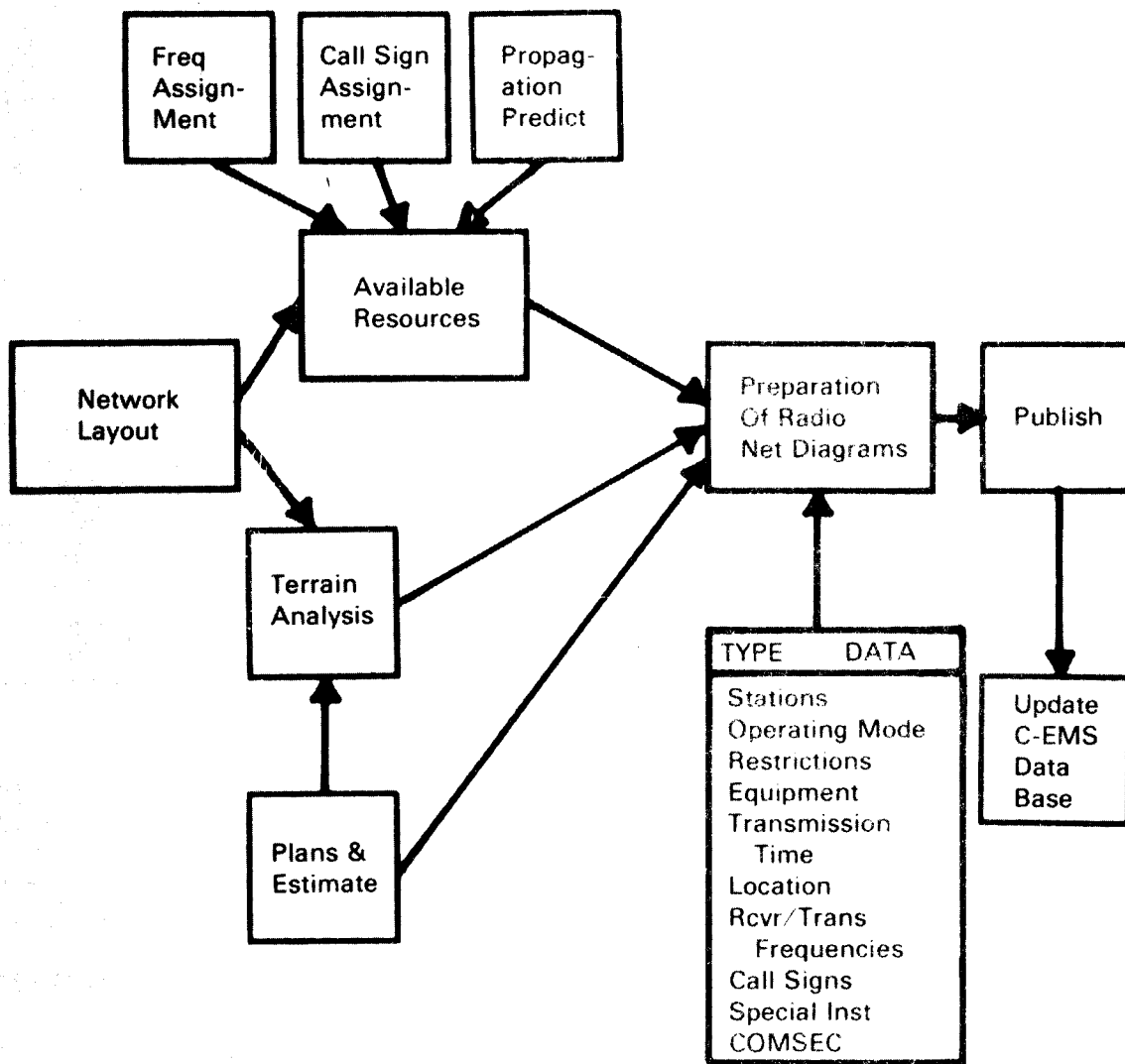

**Figure 6-10.** Procedures for Preparing Radio Net Diagrams

## 6-12. System Performance Analysis

System performance analysis (fig 6-11) is the process of collecting performance data, identifying effectiveness indicators, and evaluating the indicators to determine communications system effectiveness in meeting required standards. The primary objective of the analysis is to determine what actions, if any, can be taken to improve system performance.

**a. Collection of Performance Data.** Data is collected continuously at CSCE's based on operational reports and records; this permits frequent system performance analysis.

**b. Performance Indicators.** Indicators may be extracted directly from the raw data collected or they may be obtained after data reduction or manipulation. The performance indicators may vary with commands and networks, depending upon mission requirements, established standards, command interests, etc. Examples of performance indicators are:

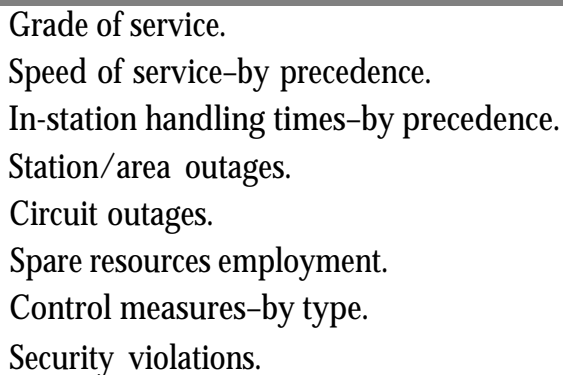

- Grade of service.
- Speed of service—by precedence.
- In-station handling times—by precedence.
- Station/area outages.
- Circuit outages.
- Spare resources employment.
- Control measures—by type.
- Security violations.

**c. Analysis and Comparison.** Performance indicators must be analyzed, along with the plans and directives that affect performance and operating capabilities, and then compared with established standards to develop the measures of system effectiveness. The standards for comparison will vary with networks and commands, depending upon available equipment, personnel, and the personnel training status. When applicable to the tactical networks, appropriate DOD and DCS performance standards pertaining to systems interface will apply.

**d. Measures of System Effectiveness.** The measures of system effectiveness may be in either quantitative or qualitative terms. They are used as a basis for determining corrective actions, as factors in estimates and plans for future operations, and as input data for submission to the Department of the Army.

**e. Responsibilities.** Each major command is responsible for analyzing the communications system performance for its area of communications responsibility through its CSPE\CSCE. Within a theater of operations, system performance analysis should be performed as frequently as necessary to insure compliance with prescribed system standards and performance criteria.

(1) The commander of the senior signal organization supporting a major command is responsible for periodically conducting an analysis that is responsive to prescribed mission objectives and operational standards prescribed by the command C-E staff. The C-E staff will review the measures of effectiveness that are developed by the signal commander for objectivity and mission accomplishment.

(2) The corps C-E section will consolidate the division and corps analyses. The theater army and corps analyses will form the basis of the system performance information provided to the Department of the Army tailored to fit CONUS needs.

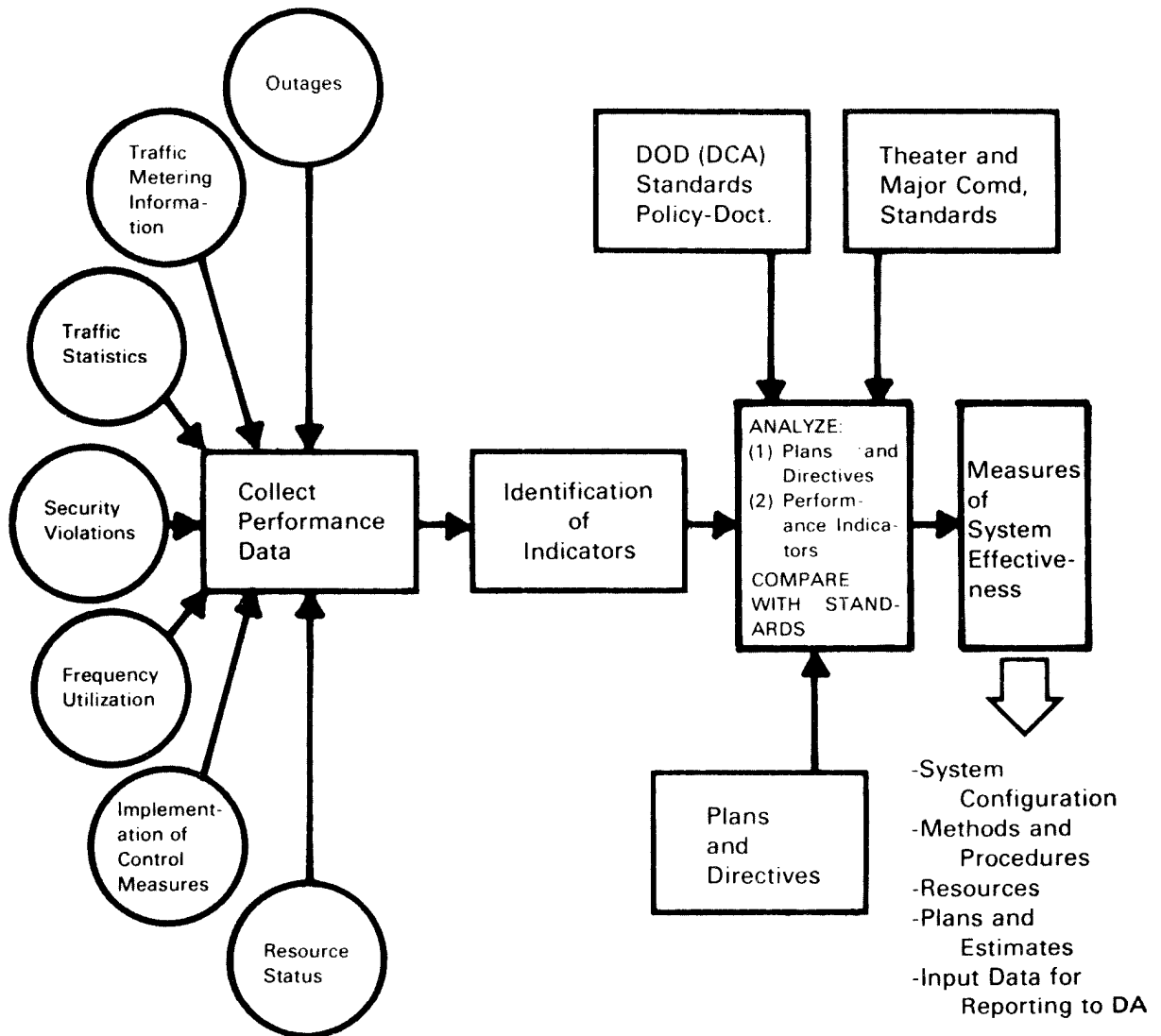

Figure 6-11. System Performance Analysis

### **6-13. Electronic Counter-Countermeasures (ECCM)**

ECCM is the function of insuring that all measures are taken to counter surveillance and maintain continuity of communications services in the presence of enemy electronic countermeasures (ECM). The primary objectives of C-EMS operations related to ECCM are the reporting of suspected ECM activities (i. e., deception and jamming) as expeditiously as possible and the prompt restoration of degraded communications.

**a. ECCM Procedures.** The following methods are used to accomplish ECCM functions:

(1) Engineering the network layouts to minimize both the surveillance of the system and the traffic that passes over the networks.

(2) Implementing operating techniques to improve overall network performance in the presence of enemy jamming. Such techniques include changes in antenna orientation, application of special modulation schemes and information transfer rates, changes of RF emission power, applications of special circuits, and switching to alternate frequencies.

(3) Modifying the network layout to reduce interference resulting from enemy jamming.

(4) Operation of special communications stations and nets and/or passing of dummy traffic to deceive enemy surveillance efforts.

**b. ECCM Responsibilities.** Overall coordination of the ECCM function for the Army in the field is the responsibility of the theater army C-E section. The corps C-E section is delegated the authority by the theater army, to consolidate ECCM information within the combat zone. The consolidated information is then forwarded to theater army headquarters.

## 7-1. Introduction

The C-EMS control functions provide direction for the use and operation of communications facilities, and directly affect the total C-E system. The CSCE and CNCE control functions discussed here complement those of the CSPE and provide direction for the CESE.

## 7-2. Communications System Control Element (CSCE)

At the higher echelons of command, the communications system control element (replaces SYSCON) is the information and direction center for all subordinate C-E systems. The CSCE maintains the data base for information needed to upgrade, modify, and manage the C-E systems. This data base may be in the form of manual reports or computer stored data. The CSCE functions are oriented toward near real-time management and control and are designed to assure the best performance of the C-E system. The CSCE prepares orders to implement CSPE planning and engineering, performs short-term traffic engineering, makes adjustments in system configuration, and resolves day-to-day troubles and system problems. The functions of the CSCE include the following.

**a. Implementation and installation.** Prepares installation orders to subordinate elements (CNCE) which will implement CSPE planning/engineering actions for:

- Installation, restoration actions, and priorities.

- General site locations.

- Radio antenna orientation.

- Quantity and distribution of essential access and trunking circuits.

- Modifications to communications links.

- Interface facilities.

- Switching, store and forward, and trunking equipment.

**b. Monitoring.** Maintains, analyzes, and displays system status information, including:

- Traffic data.

- System and equipment performance data.

- Equipment restoral status.

- Grade of service.

- Outages and backlog situations.

**c. Traffic control management.** Assures effective customer service through control measures such as:

- Routing changes.

- Trunk barrings.

- Line load controls (minimize).

- Trunk and link directions.

- Control of queues.

d. Transmission system routing control. Insures best use of resources through:

Reallocation of satellite and airborne radio relay channels.

Allocation of dedicated circuits.

Internodal routings.

Determination of number and distribution of trunking circuits.

Restoration priorities.

e. Reporting. Assembles staff guidance for the commander.

(1) This function, fundamental to efficient C-EMS operations, stems from the requirement to obtain timely and accurate information from the nodes within the network. The data should be provided by means of periodic standardized reports that can be prepared with the minimum expenditure of manpower resources. The information in the reports will be used as the basis for performing other C-EMS functions, as well as for providing inputs to data bases maintained by various elements in the C-EMS management structure.

(2) The CNCE(M) is responsible for direction and control of reporting at a communications node and should specify in an SOP the format and procedures to be used. The CNCE(M) should originate all reports from the node. Within the node, verbal reporting should be the principal means for transferring C-EMS information (written reports being used only when essential for record purposes). For reports outside the node, teletypewriter facilities are normally used, supplemented as necessary by verbal information. The CNCE(M) selects the method and channels used for the transmission of reports. Also, the CNCE(M) determines the necessity for information copies of reports to higher headquarters not in the direct channel for report transmission.

(3) The CNCE(M) collects incoming status reports on installation, equipment, personnel, traffic volume, system and circuit quality, and other related data. It also prepares outgoing status reports on system and circuit quality, fault-correction actions, equipment status, and system and circuit installation or deactivation. In addition, it prepares reports on internodal routing, rerouting, and restorals; and updates information for the CSPE and other reports as required.

f. Records keeping. Initiates, maintains, and retains the information which comprises the C-E data base.

g. Management of COMSEC resources, including keying material. This function is programed for the CY 1980 time frame.

h. Directory control. This function includes the updating and publication of directories, routing guides, etc.

### **7-3. Communications Nodal Control Element (CNCE)**

The control element at its lowest functional level, usually company, is divided into two operational sections: the communications nodal control element (management) (CNCE(M)) and the communications nodal control element (technical) (CNCE(T)).

a. The CNCE(M) is the direct arm of the commander and replaces the facilities control function. The CNCE(M) is primarily responsible for records and reports, accounting, coordination of communications requirements, and management of the communications equipment support elements (CESE).

**b.** The CNCE(T) has direct control over circuitry and replaces the technical control function. It has all the required resources to perform technical supervision of communications media and equipment, to restore lost or degraded services, to accomplish continual quality assurance of installed circuitry, and to initiate new services on receipt of proper orders (TSO). It also provides technical information to the CNCE(M) for records and reports concerning the installed circuits and systems.

**c.** For maximum efficiency, the CNCE(M) and CNCE(T) are co-located. When these elements are not co-located, the problems encountered in coordination, transfer of information, and response materially degrade the overall C-E system.

**d.** The CNCE functions include:

**(1)** Management and technical direction. Exercises management and technical direction over subordinate activities and CNCE's.

**(2)** Implementation and execution. Responds to directives from the controlling CSCE.

**(3)** Line circuit conditioning and interfacing with C-E systems.

Provides equipment necessary to condition analog and digital circuits for best performance.

Provides interface for direct current (dc) circuits, voice frequency (vf) circuits, dc-to-vf conversion, and analog-to-digital conversion, etc.

**(4)** Activation and deactivation of circuitry.

Complies with CSCE orders.

Directs subordinate activities and subscribers to execute orders.

Coordinates with other CNCE's.

Monitors circuit activation and deactivation.

**(5)** Technical coordination to accomplish quality assurance programs.

Modifies or corrects circuit configuration and coordinates changes with CSCE.

Tests installations of subordinate CESE's for adherence to established standards.

**(6)** Maintenance of systems standards.

Conducts in-service and out-of-service quality control through performance monitoring and testing.

Conducts fault isolation on intranodal, internodal, and extension facilities (DCS, allied, commercial transmission systems).

Refers fault isolation findings and corrective actions to appropriate subordinate activities.

**(7)** Rerouting and restoration of circuits, groups, and systems; updates nodal records to reflect all changes.

**(8)** Reports and reporting.

Receives reports and takes the necessary action in the areas of activation and deactivation (TSO), resource commitments, trouble conditions, performance data, test results, and facility status.

Sends reports to controlling CSCE and to appropriate subordinate

CESE's concerning activations and deactivations, trouble status, coordination with other CNCE's(T), equipment status, performance data, testing data, and system status.

**(9) Records keeping.** Records are maintained for the current deployment as opposed to the comprehensive data base maintained by the CSCE. The records include:

Circuit records with orders and technical directives regarding circuit connectivity (TSO), electrical and physical connections at the CNCE nodal facilities for which it is technically responsible, and the availability of circuits and equipment at the node are necessary for real-time operation.

System and circuit status records of all systems and circuits terminating at the node.

Nodal data base update (directories, etc.).

**e.** The CNCE(M) implements restrictive measures when traffic overloads the system. This involves the restriction of communications service to subscribers on a selective or priority basis to reduce originating traffic for certain areas. The C-E staff of each major command prepares, for the commander's approval, the broad policies for accomplishing the following:

**(1) Trunk barring.** This measure denies subscriber access to specified trunk groups. The operator at the affected node will no longer service outgoing calls on the designated trunks (manual system).

**(2) Minimize.** This administrative measure is employed to restrict selected users from the telecommunications system. A directive from the senior commander states the restrictive conditions and subscribers authorized to initiate trunk calls during periods of MINIMIZE.

**(3) Line load control.** This is a feature of automatic switches which, when activated, permits subscribers to make local calls only. Outgoing trunk calls are prohibited; incoming trunk calls are allowed.

**f.** At some staff and unit levels, implementing restrictive measures requires a planning and engineering effort. At most operating unit levels, the function is primarily a control measure that is applied at the switching central or at the telecommunications center where message traffic is originated. Each controlling CSCE should be delegated the responsibility of trunk barring and line load control within its area of responsibility consistent with established policies and procedures.

**g.** With tactical automatic telephone switches, certain features permit data base changes that provide a means of selectively limiting communications capabilities. Some of the restrictive measures available with the automatic telephone switches are line load control, changing class of service marks, and cancellation of alternate routing. Also, the switches contain a rerouting matrix that will permit rerouting of traffic in the event a distant node sustains degradation or traffic overload problems. In some switches, this is accomplished by automatic alternate routing; in others, it must be done by manually changing the routing in the data base.

**h.** The CNCE(M) establishes authentication procedures to protect information. These procedures will be necessary until total communications security is achieved. Until then, a need exists to enforce authentication procedures used for transmissions on unsecured channels. These procedures are designed to minimize enemy deception. The procedures establish who authenticates; when to authenticate; and how to authenticate. Authentication policy is developed by the Department of the Army. Army publications, AR 380-52 and DA Pam 380-150, interpret the



instructions and provide procedures for use throughout the Army. Authentication tables are generated only by the National Security Agency (NSA) and are available through COMSEC logistics channels. AR 710-2 addresses COMSEC logistics and describes procedures for request and delivery of authentication tables to major commands.

**i.** Both the CNCE(M) and CNCE(T) participate in restoring circuitry that has become substandard. This function assures the return of communications service to acceptable standards after communications failure or degradation. Participants in restoration actions are at all levels of authority and responsibility, depending on the extent of the damage and the decision level required to accomplish the recovery. Although one unit may be specifically charged with establishing and maintaining signal communications with another, both units are responsible for taking immediate action to restore disrupted communications. Restoration of service is the responsibility of the lowest level CSCE in the C-EMS organization that has control of all nodes affected by the trouble.

**(1)** Restoration starts when a trouble report is received from a node facility, remote CNCE(T), or CSCE. The CNCE(M) initiates the required actions and coordinates with, adjacent or remote nodes. Each CNCE(M) has the responsibility for restoration actions affecting its nodes, consistent with system priorities and requirements. For rapid restoration of service, the CSCE provides traffic engineering support as required to the CNCE's(M).

**(2)** The TAS system is preengineered to restore or reroute service through the use of information stored in a data base. For example, in the AN/TTC-38 automatic telephone central office, prepunched routing tapes may be used to change the routing around a damaged node. Future devices will use memory storage to accomplish the same action.

**(3)** Facility damage requires the submission of a trouble report to the CSCE by the CNCE(M). Damage may be total, such as the complete destruction of a multichannel relay or multiplex terminal; or damage may be partial, such as the loss of a major component of a terminal (power unit, spare transmitter, distribution cable), or antenna damage that produces a link degradation.

**(4)** When a facility is partially damaged, available spare components are placed in use, pending repair or replacement of the damaged items. This is accomplished at the direction of the CNCE(M). However, if damage is total, a reserve facility must be activated (as approved by the CSCE). Simultaneously, backup service will be initiated. Additional messenger service will be provided and, if needed, RATT which is normally used for control purposes will pass traffic to adjacent nodes. If jamming or interference is involved, total loss of the link might well necessitate a frequency change, as directed by the CSCE or as authorized in the CEOI.

**j.** Jamming or interference could produce complete loss of link transmission or degradation. The remedies for those problems are essentially the same as those for reported damage and could be included in contingency plans. For example, telephone, teletypewriter, or data traffic would be promptly rerouted. This could involve circuit patching by the CNCE(T) to bypass the affected node or to provide alternate routes and the transmission of teletypewriter traffic by way of alternate tape relays to and from the affected node. In the case of enemy jamming, antijamming techniques are attempted first. If available, a reserve facility might be placed into operation on a new frequency while continuing operation on the jammed frequency.

k. The CNCE(T) physically performs all patching in the control facility at the node. Patching is the installation of permanent or semipermanent connections in order to route circuits between node facilities and access points in a communications system or to redistribute them within a node. Patching may be performed to activate or deactivate service, to implement a restoration plan, or to modify the configuration of a communications system in accordance with changes in traffic loading. Patching can also route a multichannel group directly through a node as part of a traffic engineering plan to bypass a damaged portion of the system. Patching is performed by a CNCE(T). There must be close coordination throughout the implementation process. When a system is engineered, it should be designed so that most circuits are "normal-through" where possible. Patching is performed by a CNCE(T).

(1) When patches are made on a system involving two or more nodes, the requirements are determined by the CSCE performing traffic engineering of the system. The controlling CSCE must initiate the necessary plan and coordinate its implementation through CNCE's(M) at the nodes. Coordination of system patching will be done as necessary between CNCE's(T) at terminal and relay points. Senior signal unit CSCE's are responsible for maintaining a record of all internodal circuit and group patching that they have ordered at nodes within their area of responsibility using the communications control journal (DD Form 1753) and TSO's.

(2) The CSCE's should delegate to nodal commanders the authority to change circuit patches on extension systems installed and operated by the nodal commanders. In addition, CNCE(T) may make circuit changes within a node when they do not affect system capabilities. The CNCE(T) will maintain, on a current basis, a system and circuit record of all patching accomplished at the node.

l. The CNCE(T) tests all circuits and systems according to a schedule dictated by the CNCE(M). Testing is performed on circuits to insure that they meet performance standards prior to implementation of service. Testing is also performed to identify the source of a disruption of service (fault location), to ascertain the extent of damage or degradation, and to verify that required standards of service are being provided after restoration.

(1) The testing process can be initiated as the result of monitoring, the receipt of a trouble report, or by direction of the CNCE(M), based upon a request that originated from outside the node. Facility operating personnel (CESE) will perform testing by using either the auxiliary test equipment or the testing capabilities designed into the system. In some cases, test equipment located in facilities other than the CNCE(T) may be used. Authorization for the use of those facilities is arranged through the CNCE(M).

(2) The testing of circuits is performed according to established procedures. Some circuits may be tested while they are in use. All users of these circuits **MUST BE NOTIFIED PRIOR TO TESTING**. Others must be tested when not in use to prevent the false triggering of alarm circuits within the equipment. In all testing of circuits involving the TAS, the circuit controller in the CNCE(T) must coordinate with the TAS personnel prior to testing. Failed circuits are retested as soon as possible. Restoration is based upon the priority rating of that circuit. of that circuit.

(3) All test operations related to internodal circuits are monitored and coordinated by the circuit controller at the CNCE(T). The installation and maintenance personnel assigned to a node should be directly

responsible for the testing and maintenance of the intranodal communications system.

(4) The CNCE(T) should record the results of testing received from operating facilities (CESE) or other CNCE's(T) on a system and circuit status record.

(5) The CNCE(T) will report the test results to the CNCE(M), which in turn may report to the CSCE. For significant outages, reports may be rendered up through the entire communications chain. For lesser troubles, such as a single (nondedicated) channel or a local telephone problem, reports are generally limited within the node. However, the CNCE(T) of the node should be informed promptly of any testing within the node that is related to actual outages or trends toward interruption of service.

**m.** The CNCE(T) monitors circuits on a continual basis. This function is for the purpose of observing the performance of communications facilities in order to detect indicators of inadequate performance or to detect trends leading to degradation in performance. Monitoring, an inherent element of facility operation, can be accomplished as prescribed by SOP, as directed, or during performance of preventive maintenance. The function involves observation by operating personnel or by automatic metering, alarms, or monitoring devices built into facility equipment and auxiliary devices.

(1) All operating facilities of a node are monitored, including multichannel transmission terminals and relays, multichannel radio and cable extension links, multiplex equipment, automatic telephone switches, and the teletypewriter/data facilities of the terminal and the tape relay sections. When monitoring of TAS circuits could result in triggering of alarm circuits, TAS personnel must be notified.

(2) The CNCE(M) has overall responsibility for the proper accomplishment of monitoring at a node and should provide appropriate SOP guidance for the operating facilities.

(3) The CNCE(T) is responsible to the CNCE(M) for monitoring the performance of all internodal circuits. The CNCE(T) maintains a system and circuit status record. This record shows the status of systems and circuits terminating at the node. The CNCE(T) will rely mainly on operating facility personnel (CESE) to report any noted link or equipment outages or degradation. Monitoring results are reported by operating personnel to the CNCE(T) as required by local procedures or as directed by the CNCE(M). The CNCE(T) reports to the CNCE(M) which, in turn, may relay the information in the appropriate format to a CSCE. However, all monitoring results should not necessarily be reported outside the node. The CNCE(M) makes the decision as to when monitoring results will be reported to the controlling CSCE.

#### **7-4. C-E System Deactivation**

**a.** The following establishes guidelines for commanders when closing down a system. The primary objective is to insure that everyone involved is properly notified of closure time, procedures, actions, and directions to follow before, during, and after the closure. There are two methods of notification: normal chain of command channels and technical control channels.

**b.** Overall responsibility for closure rests upon the commander of the system. He delegates this responsibility downward, through both the chain of command and the technical control channels (C-EMS), to rest finally with the CSCE and CNCE's directly involved in the deactivation of the system.

c. The closing of a C-E system, or any portion of it, is a control procedure and requires close coordination between all elements of that system. Past experience shows that the process of closing a C-E system can vary from a smooth operation to a gigantic “snafu.” The experience level of the personnel controlling and operating the systems is a critical element; and because experience varies from person to person, a precise method of control is required.

d. Closure orders which include the activities involved, closure times, and actions to be followed after the closure are sent to the CSCE and CNCE’s. Both command and technical control channels are used to insure that everyone involved “gets the message.”

**SECURITY NOTE:** All orders or instructions relative to closing down the C-E system must be authenticated according to instructions provided by the CEOI. This requirement applies regardless of how the instructions or orders are issued.

e. The CSCE, acting through the controlling CNCE, directs and supervises the closing of the system. The CNCE, in turn, notifies all subscribers of the closure time. Normal chains of command, engineering orderwire, and other engineering channels are used to notify all systems, relays, and subscribers, including users of “strap-through” and “dedicated” (sole-user) circuits.

f. When closure time occurs, the CSCE/CNCE’s direct subordinate units to terminate subscriber service. The CNCE verifies termination of all subscriber service and notifies the CSCE. The activation/deactivation reports may be used to conclude this action; if the situation permits or warrants it, however, verbal notification will suffice.

g. After the CSCE receives verification of subscriber termination, the CSCE notifies the controlling CNCE to begin closing down the trunking system. The CNCE then directs operating personnel of the terminal equipment (carrier, multiplex, or radio) to notify all relays and terminals in the system to close down. Each one closes, in turn, beginning with the most distant point, thus assuring that all units in the system are notified of the action to close and, in fact, do close.

h. After receiving verification that the entire system has closed, the CNCE files an activation/deactivation report with the CSCE and then closes down. The CSCE, at this point, records the time of closure and reports to higher headquarters that the system is closed, and any communication required is over single channel radio nets.

**Department of Defense (DOD) Regulation**

(C) 4605.2

5200.1-R Information Security Program Regulation

**Department of the Army Regulation**

310-20 Military Publications—Allied Communications Publications (ACP) and Joint Army, Navy, Air Force Publications (JANAP)

**Department of the Army Pamphlets (DA Pam)**

310-1 Military Publications—Index of Administrative Publications (Regulations, Circulars, Pamphlets, Posters, JCS Publications, and General Orders)

310-2 Military Publications—Index of Blank Forms

310-3 Military Publications—Index of Doctrinal, Training and Organizational Publications (Field Manuals, ROTC Manuals, Training Circulars, Army Training Programs, Army Subject Schedules, Army Training Tests, Firing Tables and Trajectory Charts, Tables of Organization and Equipment, Type Tables of Distribution and Tables of Allowance)

310-4 Military Publications—Index of Technical Manuals, Technical Bulletins, Supply Manuals (Types 7,8, and 9), Supply Bulletins and Lubrication Orders

(O) 310-9 Index of Communications Security (COMSEC) Publications (U)

# Telephone Numbering System, Transmission System Designation, and Circuit Identification

### **B-1. Tactical Telephone Numbering Plan (TTNP)**

The introduction of automatic switching into the tactical communications-electronics system requires a new approach to the telephone numbering scheme. The plan presented in this appendix has been modified based on user comments and experience gained through the use of automatic switches AN/TTC-25 and AN/TTC-38.

a. This plan was developed following the guidelines provided in MIL-STD-188C, 24 November 1964, and is a primary zone (PR) switch locator (SL) oriented system. It has widespread impact on areas other than automatic switching, because of the limited number of automatic switches in the current inventory and the number of manual switches with which it must permit interface in the automatic voice network (AUTOVON), as well as C-E systems engineering considerations.

b. The plan, as presented, provides the basis for future numbering plans which must be devised to function within the scope of equipment under development; e.g., AN/TTC-39, SB-3614/TT, and unit level switches (ULS). These are expected to be fielded in the 1980's. Furthermore, the system evolving (from practical experience) must take into consideration the requirements of INTACS, EAD, and the TRI-TAC systems of the future. Factors to be considered include: proposals by allied/NATO forces for a 13-digit system, the capability of the AN/TTC-39 to provide 10 digits from AN/TTC-39 to AN/TTC-39; the existing 13-digit Allied/NATO elements system; and seven digits down to the level of the AN/TTC-38's, SB-3614/TT's, and ULS's. Finally, under TRI-TAC, the entire theater of operation must eventually use a system that is common to Army, Navy, Air Force, Marines, and DCS.

c. The tactical telephone numbering plan (TTNP) provides for the assignment of PR's by geographic location, thereby allowing each PR to serve a maximum of 100 (00-99) switch locations (SL's). Geographic areas requiring more SL's than are provided may be assigned additional PR's, as required. PR assignment is the responsibility of the theater communications system planning element (CSPE). Restriction of PR assignment is limited to a single PR. 99; it is used only for providing subscriber access to the fixed directory system inherent in the TTNP.

d. Management and planning requirements are simple. Any PR (70-98) may be assigned to any selected geographic location. Grid assignment is probably the best method of assignment. Under this method, SL's become the primary identification for command posts, area signal centers, peripheral organizations, miscellaneous facilities, installations, combat units, and combat support and combat service support units (brigade level and higher).

e. The basic TTNP is covered in FM 24-26, *Tactical Automatic Switching*, which allows for 29 PR numbers (70-99), SL numbers are 00 through 99. The PR is synonymous with the "area code" numbers of the commercial telephone systems, and SL is synonymous with the exchange portions of the numbers.

### Basic Numbering Plan

<b>TACTICAL</b>	<b>Primary Zone (PR)</b>	<b>Switch Locator (SL)</b>	<b>Terminal Number</b>
PR + SL + XXX	= 2 Digits (XX)	2 Digits (XX)	3 Digits (XXX)
<b>COMMERCIAL</b>	<b>Area Code</b>	<b>Exchange Number</b>	<b>Terminal Number</b>
XXX + XXX + XXXX	= 3 Digits (XXX)	3 Digits (XXX)	4 Digits (XXXX)

So, while commercial systems use 10 digits for long distance call identification, the tactical numbering plan uses only seven. However, this may not always be true. Future systems, as they are expanded, may require that primary zones use a three-digit code similar to commercial area codes.

f. In commercial systems, a subscriber is normally identified by the exchange number plus the terminal number (a total of seven digits). In the tactical system, a subscriber is normally identified by the entire PR-SL XXX number (also seven digits).

<b>Digit Position</b>	<b>General Application</b>	<b>General Assignment</b>	<b>Available Number</b>
PR	Primary zone or geographic area	Geographic areas as directed by theater CSPE	70-99
SL	Switch location used as a secondary identification within a given PR (can be either automatic or manual)	Command posts, ASC's peripheral organization/installations. Miscellaneous facilities. Combat units, combat support, and combat service support units (bde level and higher)	00 thru 99

## B-2. System Designation and Circuit Identification

Both system designation and circuit identification numbering schemes will eventually be standardized worldwide. The plan presented here, however, is intended to allow the flexibility for future systems that may require either an expanded tactical telephone numbering plan or system/circuit identification system.

This system designation and circuit identification plan allows the theater planning element to assign site (node) numbers to each unit with the theater. Future application of system and circuit identification may require that the origin and destination be indicated using the PR-SL. This is currently being considered as part of the data base requirements for the tactical communications control facilities (TCCF). Space availability in the TCCF computer is presently established for 7, 9, and 11 character bits to be used for circuit and system identification numbers.

As development of future equipment is completed, development of a compatible and complementary numbering system to match that equipment must also be accomplished. The current plan allows for that expansion. Further, the plan uses the DOD method of priority designation in both systems and circuits and it is used on the circuit routing list (CRL).

## B-3. System Designators

The system designator consists of seven characters. This number identifies the origin and destination of the system and the type of system.

a. The originating terminal is the control terminal for installation and restoral purposes.

Characters 1 and 2:	Indicates originating terminal by site designator; also represents the control terminal (sometimes designated as "A" terminal).
Characters 3 and 4:	Indicates destination terminal, also by site designator; also represents the noncontrol terminal (the terminal subordinate to the directives of the control terminal, sometimes designated "B" terminal).

b. Each signal site (node) has a designator consisting of either two or three characters. These site designators are assigned in accordance with guidance established by the theater army C-E staff. (For the purposes of discussing the numbering plan in this appendix, USAREUR site designators are used as examples.) *The theater CSPE (or responsible planning element) must assign identifying digits to all units and promulgate this as a part of the C-E SOP.* At division level and higher, each major command is assigned a unique letter designator as the first character of its site designator. This provides the advantage of identifying any terminal site having a first letter designator of "R", for example, as a 3d Infantry Division unit. The second digit then identifies the specific site.



(1) First characters of two-digit site designators:

A:	7th Signal Brigade
B:	11th Armored Cavalry Regiment
C:	32d Army Air Defense Command
D:	1st Infantry Division
E:	1st Armored Division
J:	VII Corps
P:	8th Infantry Division
R:	3d Infantry Division
S:	3d Armored Division
U:	USAREUR/7th Army
V:	V Corps

(2) Second characters of two-digit site designators:

1:	Signal Main
2:	Signal Alternate
3:	Artillery Battalion
4:	Artillery Group
5:	Armored Cavalry Regiment
6:	Support Command
7:	Engineer Brigade
8:	Aviation Battalion
9:	Spare
0:	Base
A-F:	Main/TOC Locations
Y, Z:	Tac/Alt/Fwd CP Locations
G:	ADA Group
J, K, L:	Demods
M:	1st Brigade
N:	2d Brigade
P:	3d Brigade
R:	4th Brigade/Separate Brigade
S:	5th Brigade/Separate Brigade

c. Site designators of terminals within the COMMZ will consist of two numerical characters, assigned as follows:

00-49:	Army area signal centers
50-69:	USAREUR subordinate units within COMMZ

70-79:	Theater army signal battalions
97:	CENTAG
80-96, 98-99:	Spares, assigned to corps/division units

(1) Character 5 indicates system type:

- C - Cable with PCM multiplex
- H - HF multichannel
- K - Satellite multichannel
- M - Microwave radio with PCM multiplex
- P - UHF radio with PCM multiplex
- T - Troposcatter radio with PCM multiplex
- U - Mixed system with PCM multiplex
- V - UHF radio with FDM multiplex

**NOTE:** Future systems may require additional letter designator(s) for new system types.

(2) Character 6 indicates identical systems between two system terminals:

- A - 1
- B - 2
- C - 3
- D - 4
- E - 5
- F - 6
- G - 7
- H - 8

(3) Character 7 identifies the 12-channel group number (and shows the number of channels):

- A - 1st 12-channel group
- B - 2
- C - 3
- D - 4
- E - 5
- F - 6
- G - 7
- H - 8

(4) System Number Example (using USAREUR units):

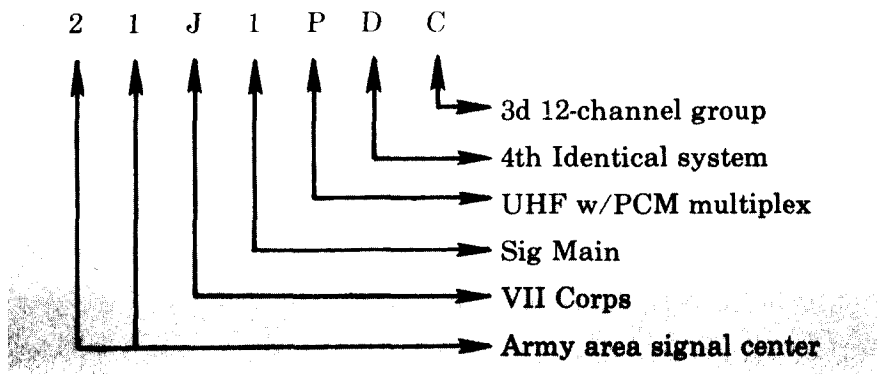

d. On CRL's and other forms and reports where system identification is required, the system designators for 12-channel groups will be used as opposed to a designator for an entire system. If an entire system must be identified or represented, the designator for the last 12-channel group on the system will be used. For example, a 96-channel UHF radio-PCM system between site 21 and site J1 would be 21J1PAH. Designators 21 and J1 identify the sites; P identifies UHF radio with PCM MUX; A indicates there is only one system of this type between the two sites; and H means there are eight 12-channel groups (or 96 channels). Each of the 12-channel groups (the identification normally needed by operating personnel) would appear on the CRL as separate designators 21J1PAA (1st 12-channel group), 21J1PAB (2d 12-channel group), 21J1PAC (3d 12-channel group), 21J1PAH (8th 12-channel group). A second 96-channel system would be identified 21J1PBH.

e. Three-digit site designators, assigned to relays, are used to identify relays that do not drop or insert channels, hence will never appear in a system designator.

100-499:	Army Area
500-599:	V Corps
600-699:	Spares
700-799:	VII Corps

#### B-4. Circuit Designators

a. The circuit designator consists of seven characters. The designator identifies the circuit type, the origin and destination of the circuit, and the use of the circuit. The originating terminal is, arbitrarily, the control terminal. Figure 1 provides information for assigning characters 1, 6, and 7. Characters 2, 3, 4, and 5 are derived from the system designator digits lists.

b. The format for circuit designators lends itself to application in existing nonautomated systems and can be expanded or modified for future TRI-TAC systems. As examples of this, characters are reserved for sole-user circuits because, at the present time, sole-user circuits are a command necessity. Sole-user circuits will not only be unnecessary in the TCCF plan but would actually provide degraded service. Also, although no 32kbs circuits are in use now, a 7th digit character is provided for 32kbs identification, because future systems will use that rate. The alphanumeric characters shown in figure 1 as "spares" may be used for designation of characteristics not otherwise identified.

Digit 1	Digit 2 & 3	Digit 4 & 5	Digit 6	Digit 7
Circuit Type	Originate Terminal	Destination Terminal	Subscriber or Terminal Equipment Identification	
1 Sole User (2W-2W) 6 Sole User (4W-4W) 7 Long Local (4W-2W) 8 Long Local (4W-4W) 9 Long Local (2W-2W)	USE		1 G/S1 2 G/S2 3 G/S3 4 G/S4 5 XO 6 Cdr 7 AVN 8 Spare 9 C-E Off 0 Spare  A CSCE B CNCE(T) C CNCE(M) D RWI E TOC F NWLE G SASP H CBRE I Not Used J SSG  K SSO L Spare M Spare N Spare O Not Used P Spare Q Spare R Spare S Spare T Spare  U Spare V Spare W Spare X Spare Y Spare Z Other	
2 Common User (2W-2W)	SITE		01-10 Man Swbd/Man Swbd 31-40 TAS/Man Swbd 11-20 Man Swbd/DSA 41-50 Spare 21-30 TTC-41/Man Swbd 51-60 Man Swbd/TTC35	61-65 TAS/DCO(Dial) 66-90 Spare 91-99 TAS/DSA
3 Common User (4W-2W)	DESIGNATORS		01-20 TTC-35/Man Swbd 31-90 Spare 21-30 TAS/Man Swbd 91-99 TAS/DSA	
4 Common User (4W-4W) 5 Spare 0 Spare	FROM		01-15 TTC-35/TTC-35 41-45 TAS/VCN 16-30 TAS/TTC-35 46-50 Spare 31-40 TAS/Man Swbd 51-60 TTC-41/TTC-41	61-70 TAS/TTC-41 71-90 TAS/TAS 2250 Hz 91-99 TAS/DSA 2250 Hz
A Sole User Teletype B MODE I DSTE C MODE II DSTE D MODE V DSTE E Man Data F Facsimile G Common User Teletype H Special Category I & O Not used J-Z Spare	SYSTEMS  LISTINGS		1 MR/MR 2 MR/TCC 3 TCC/MR 4 TCC/TCC 5 TADS/MR 6 MR/TADS 7 TADS/TCC 8 TCC/TADS 9 TADS/TADS 0 TADS/ASC A ASC/TADS B ASC/TCC C ASC/MR  D Spare E Spch Plus F Spare G ASA/ASA H SSO/SSO I & O Not Used J-Z Spare	1 HDX 2WVF 60 wpm 2 HDX 2WVF 66 wpm 3 HDX 2WVF 100 wpm 4 HDX 4WVF 60 wpm 5 HDX 4WVF 66 wpm 6 HDX 4WVF 100 wpm 7 FDH 4WDC 60 wpm 8 FDH 4WDC 66 wpm 9 FDH 4WDC 100 wpm 0 Facsimile A FDH 4WVF 60 wpm B FDH 4WVF 66 wpm C FDH 4WVF 100 wpm  D 150 bps E 300 bps F 600 bps G 1200 bps H 2400 bps I Not Used J-2 Kbs K 16 Kbs L 32 Kbs M Spare N Spare O Not Used P-Z Spare

**Figure B-1. Circuit Numbering Scheme**

c. The following examples illustrate the flexibility of this circuit numbering plan.

**EXAMPLE 1.** A common-user (4W-4W) telephone trunk from 8th Inf Main TTC-41 to TTC-38 at V Corps COSCOM (control terminal).

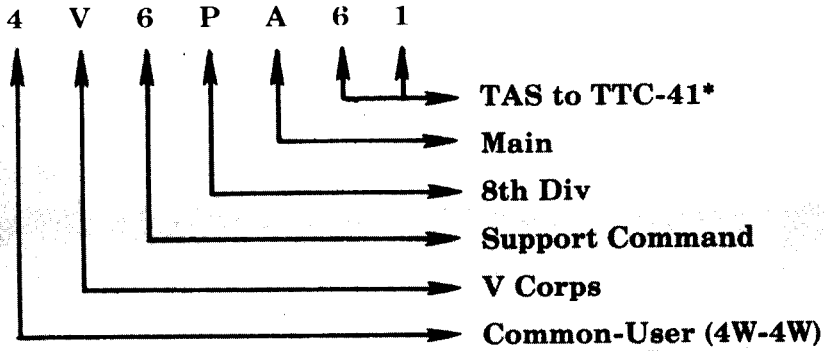

\*61 indicates that this is the first circuit of this type between these points.

**EXAMPLE 2.** A sole-user (2W-2W) telephone circuit from 1st Bde, 3d Inf Div Cdr to G3, 3d Inf Div (control terminal).

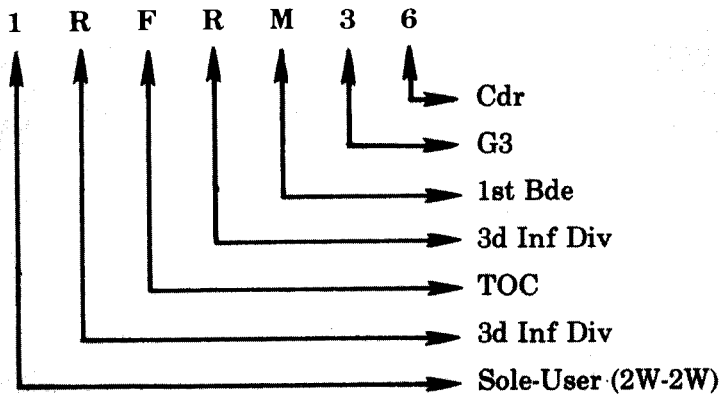

**EXAMPLE 3.** A common-user teletypewriter circuit (FDX Crypto 4WVF 100 WPM) from TADS at the army area signal center (designated 36) to the 32d AADC Main CP (control terminal) telecommunications center.

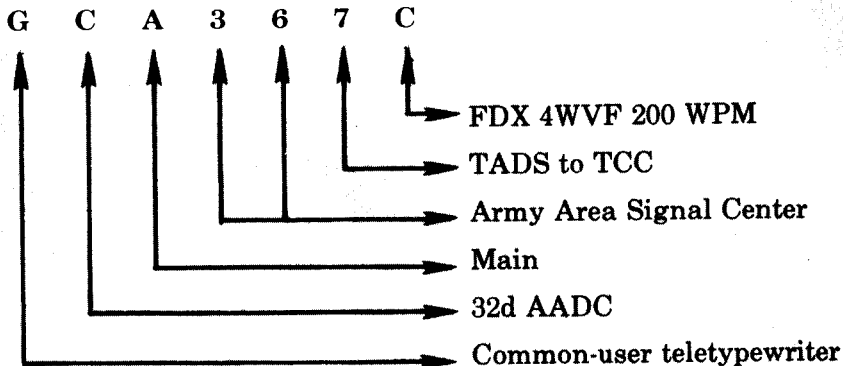

**EXAMPLE 4.** A facsimile circuit from 3d Armored Division Aviation Battalion to USAREUR/7th Army Main (control terminal).

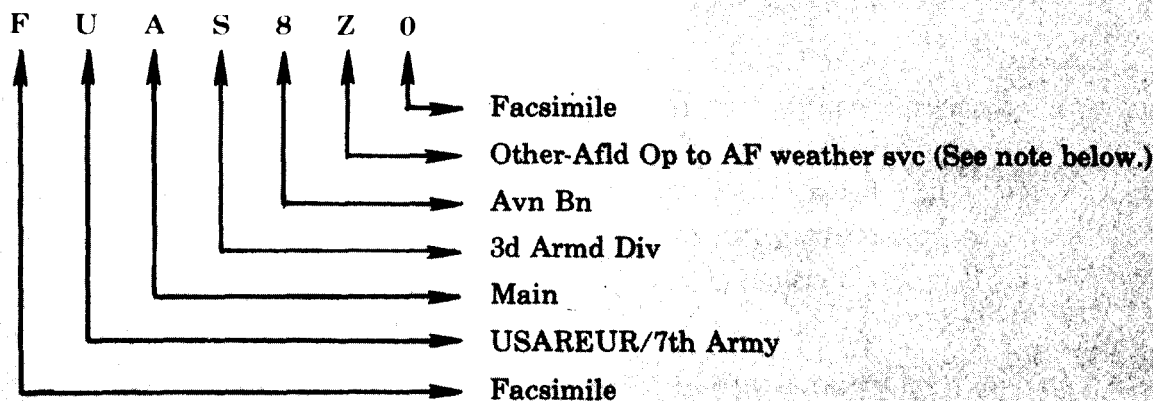

**Note:** When the character indicating "other" is used, explanation can be made on CRL. When the new family of digital facsimile equipment is fielded, additional identifiers (characters) will be made (using spares) to provide essential circuit information.

d. Using this format as shown in the examples, an operator or technical controller can readily tell the difference between telephone service circuits and digital service circuits by the first digit of the circuit number. All telephone circuits have a numerical digit as the first character; all digital service circuits (teletypewriter, data, etc.) have an alpha digit as the first character.

e. When multiple, identical digital service exists between two points, the spare digits available for the 6th digit can be used to identify the individual circuits. For instance, four teletypewriter circuits installed between two manual relays could be identified as GXXXX1C, GXXXXJC, GXXXXKC, and GXXXXLC, noting that here the spare digits J, K, and L are used. When spare digits are to be used, the theater CSPE should prescribe their use based on the theater need for multiple circuits between points.

## B-5. Priorities for System and Circuit Restoral

a. Each system and circuit in the C-E network is assigned an alphanumeric priority indicator dictating its installation sequence and restoral priority. This number, consisting of two characters, appears in the priority indicator (PRI) column of the circuit routing list (CRL). System planners and engineers are responsible for assigning circuit and system priorities and should include the priority assignments in the CRL.

(1) System Priority—The priority of any system will be the same as the highest priority circuit on that system (excepting control circuits). An absolute chronological order for system restoration is unnecessary. The CSPE must insure that backup circuits are not assigned to the same system as primary circuits to provide uninterrupted communications.

(2) Circuit Priority—The priority of a circuit is established and assigned by the planning/engineering element, based on guidelines established in DOD Directive 4605.2 (Confidential).

b. The designators have digit 1, 2, 3, 4, or 0 as the first character to indicate priority. Subpriorities are assigned by using letters A through I as the second character. These characters show restoration objectives as follows:

CATEGORY 1 (ALL) .....	Immediate
CATEGORY 2 (ALL) .....	10 minutes
CATEGORY 3A .....	20 minutes
CATEGORY 3B .....	1 hour
CATEGORY 3C .....	6 hours
CATEGORY 4A .....	24 hours
CATEGORY 4B .....	72 hours
CATEGORY 00 .....	After all others

c. Designators authorized for use in tactical systems are:

1A 2C 3A 4A 00  
1C 2D 3B 4B  
1D 2F 3C  
1E 2H  
1F 2I  
1G

DOD Directive 4605.2 (Confidential) describes the use of the above codes. The above listed designators are the only ones normally used in tactical systems.

**Notes: 1.** The single most important circuit of any system is the engineering/control circuit. It does not, however, establish the priority of the system. The priority of the system is established by the CSPE as stated above. Under this system, all engineering circuits carry a 1A priority.

**2.** Some categories may be assigned only by the theater army CSPE and are used only when highest level requirements must be met. These are described in DOD Directive 4605.2 (Confidential).

d. To derive the priority indicator, the planner/engineer must identify the type of circuit, the using unit, and the subscriber. He then must make a judgment as to the relative importance of the circuit in accordance with DOD Directive 4605.2 (Confidential).

(1) Once a priority assignment is made, it then is the responsibility of the tactical circuit controller to install and maintain those systems/circuits in accordance with the priority and restoral codes. However, it must be stressed again that the circuit controller must use common sense and good judgment at all times. He must assess the situation and, using technical knowledge and experience, restore systems and circuits using all available resources. This means the controller must be aware of available spare equipment, the locations and commitments of maintenance teams, and the capabilities of the various peripheral elements to respond to trouble conditions. Further, based on this knowledge, the controller must correct or direct the correction of faults that can be handled on an immediate remedial-action basis. The controller who knows system configurations will realize that dispersal of maintenance teams to locations within the zone of responsibility takes more time than replacement of printed circuit boards or realignment of a system.

**(2)** In addition, realizing that each case of trouble is different, the controller should act accordingly to restore circuits of equal priority. Nonetheless, he cannot ignore circuits of lesser priority while waiting for high priority circuit or system repair. Only in remote cases will the requirement for a management decision on restoral priorities surface; but when it does, the management element of the CNCE will be responsible for decisions as to which priority circuit/system is to be restored first.



# Special C-EMS Forms

## C-1. Introduction

The special forms in this appendix are designed to facilitate C-E management based on the interrelationship between headquarters, signal units, and control centers throughout the Army in the field. Effective C-E management requires maintaining essential records at key locations and a flow of reports and directives between elements of the system.

**Note:** Forms that contain classified information, such as the locations of facilities or units, unit designations, frequencies used, etc., must be classified CONFIDENTIAL or higher. They must be handled in accordance with security regulations.

## **C-2. Communications System Information Summary**

The communications system information summary specifies the format and content for rendering periodic reports by the Army in the field that may be used by Department of the Army for long range planning, research and development, programing procurement schedules, and for preparation and modification of doctrine. This summary is a permanent record of C-EMS operations addressing system status and performance, use of equipment and supplies, personnel and training, experience data, and user requirements. It is prepared at theater army and the senior combat zone command (corps). The information contained in the report is derived from the system performance analysis and the equipment and personnel records of the command and supporting senior signal unit. The recommended format for the communications system information summary in outline form is shown in figure C-1.

**a.** The first three paragraphs identify the command preparing the summary, the date prepared, and the period covered by the summary.



**b.** Paragraph 4 addresses the TOE/TDA organizational structure of the signal units in the command. New and excess organizational requirements are projected and the organizations, TOE/TDA, and number affected are identified together with the projected requirement data. For those units projected to be excess, a proposed disposition of the resources will be stated. This paragraph will also identify recommended changes and modifications to existing TOE's and TDA's.



**c.** Paragraph 5 identifies projected new and excess personnel resource requirements, recommends changes to TOE/TDA personnel authorizations, and identifies special qualifications, skill levels, grade requirements, and requirements for new military occupational specialties (MOS).



**d.** Paragraph 6 identifies projected new and excess equipment resource requirements by major critical end items. This paragraph also identifies special requirements for nonstandard items, recommends changes to TOE/TDA equipment authorizations, and lists the status of the deployment and theater test and evaluation of new equipment introduced into the theater command.



1. From
2. To
3. Summary Period: From; To
4. Organization (TOE, TDA, Separate Teams)
  - A. New Requirements Projections  
Title; Number; Quantity; Date Required
  - B. Excess Requirements Projections
    - (1) Title; Number; Quantity; Date Excess
    - (2) Disposition
  - C. Recommended Changes to Unit Compositions  
Table Number; Title; Modification
5. Personnel (By Team and/or Critical MOS)
  - A. New Requirements Projections  
Team Code/MOS; Title; Grade; Quantity; Date Required
  - B. Special Qualifications Requirements
  - C. Recommended Changes to Personnel Authorizations  
Table Number; Title; List Number; Modification
  - D. New MOS Description/Skill Level/Grade Requirements
  - E. Excess Requirements Projections
    - (1) Title; Grade; Quantity; Date Excess
    - (2) Disposition
6. Equipment
  - A. New Requirements Projections (Critical Items)
    - (1) Electronics  
Team/Major End Item; Type/Model; Quantity; Date Required
    - (2) Power  
Team/Major End Item; Type/Model; Quantity; Date Required
    - (3) Ancillary  
Team/Major End Item; Type/Model; Quantity; Date Required
    - (4) Miscellaneous  
Team/Major End Item; Type/Model; Quantity; Date Required
  - B. Special Requirements (Nonstandard Items)
  - C. Recommended Changes to Equipment Authorizations  
Table Number; Title; Line Number; Modifications

---

**Figure C-1.** Format for Communications System Information Summary

e. Paragraph 7 evaluates the communications systems performance. The traffic handling assessment addresses the command and area communications systems separately. For both systems, the total number of telephone calls by precedence are reported for the period together with the percent change from the last period, the system grade of service, and the average holding time. Problem areas are identified and analyzed with respect to the system, switches, and trunks. A qualitative evaluation statement is made concerning the acceptability of the grade of service and means to improve the system performance. For both systems, the total number of teletypewriter messages and the number of data cards by precedence are reported for the period together with the percent change from the last period and the speed of service based on elapsed time between filing time (TOF) and transmission time (TOT). Problem areas are identified and analyzed with respect to the terminal and relay facilities, and a qualitative statement is made concerning the acceptability of the communications service provided. Similar kinds of information will be included for facsimile, closed circuit television, and messenger/courier services. Subparagraph B identifies special system problems, such as system security, radio frequency interference, system interface, and allied/indigenous interface considerations. Subparagraph C may be used to recommend doctrinal changes and to report changes to the command on unit SOP based on an analysis and evaluation of operating problems encountered. Subparagraph D addresses frequency resources, identifying new frequency requirements, and frequencies found to be excess to requirements. Use of automated frequency management procedures to provide CEOI items will be reported in a narrative summary as well as transmission anomalies peculiar to the area of operations and other frequency problem areas.



f. Paragraph 8 will address logistic support of the communications systems; in particular, critical supply and maintenance requirements, special transportation and handling requirements, special CONUS and/or offshore procurement requirements, as well as the recovery and reclamation of C-E materiel.



- D. New Equipment Introduction
  - (1) Status of Theater Test and Evaluation
  - (2) Status of Equipment Deployment
- E. Excess Requirements Projections
  - (1) Team/Major End Item; Type/Model; Quantity; Date Excess
  - (2) Disposition
- 7. System Performance
  - A. Traffic Handling Assessment
    - (1) Command System
      - (a) Telephone Calls
        - 1. Total for reporting period by precedence.
        - 2. Percent change from last period by precedence
        - 3. Grade of service
        - 4. Average holding time
        - 5. Problem analysis
        - 6. Qualitative evaluation statement
      - (b) Teletypewriter Messages
        - 1. Total for reporting period by precedence
        - 2. Percent change from last period by precedence
        - 3. Speed of service
        - 4. Problem analysis
        - 5. Qualitative evaluation statement
      - (c) Data Cards
        - 1. Total for reporting period by precedence
        - 2. Percent change from last period by precedence
        - 3. Speed of service
        - 4. Problem analysis
        - 5. Qualitative evaluation statement
      - (d) Other
        - 1. FAX
        - 2. Closed circuit TV
        - 3. Messenger/courier
- 8. Logistics
  - A. Supply Requirements
  - B. Maintenance Requirements

---

**Figure C-1 (Cont)**

**g.** Paragraph 9 will depict the status of the command training structure consolidated by level of command. Subparagraph A presents the command schooling status in terms of the MOS and non-MOS training courses that are conducted by the command. Subparagraph B projects the CONUS student output to the command that is required to satisfy MOS requirements, based on anticipated personnel rotation, losses, and operational requirements projected by paragraph 5A. Subparagraph C provides recommendations for changes in the POI for CONUS schools based on operational experiences. The purpose of these recommended POI changes are to provide the command with course graduates better qualified to assume assigned organizational duties with a minimum of OJT or other additional training. Subparagraph D provides recommendations for the establishment of new courses (both MOS producing and non-MOS courses) to develop skills which cannot be provided by modification of existing school courses.



**h.** Paragraph 10 gives considerations that may influence budget and program actions by Department of the Army. Subparagraph A discusses new project requirements, such as new stations/facilities, new systems, class IV signal projects, and associated construction. Subparagraph B reports on the status of current projects, to include the funding of projects being performed by both military and civilian contractor effort. Subparagraph C identifies projects completed during the reporting period and evaluates their impact on the communications systems. Subparagraph D projects contractual support requirements for goods and services, and reports and contractual obligations incurred and the funding status of contractual support during the reporting period.



**i.** Paragraph 11 provides general information not covered by the other paragraphs of the communications system information summary. This information may identify test and evaluation programs in progress in the command, report the status of these programs, and provide an evaluation of the results as they impact the command mission. Additional information can include such items as recommended doctrine and policy changes and requirements for publications and manuals essential to the operation of the communications systems.



- C. Special Procurement Requirements
  - (1) CONUS
  - (2) Offshore
- D. Transportation and Handling Requirements
- E. Recovery and Reclamation of C-E Material
- 9. Training
  - A. Command and Schooling Status
    - (1) MOS Courses
    - (2) Non-MOS Courses
  - B. CONUS School Student Projections
    - Course Number; MOS; Quantity; Date
  - C. Recommended Changes to POI's
  - D. New Course Requirements
- 10. Budget and Programing Considerations
  - A. New Project Requirements
  - B. Status of Current Projects
  - C. Projects Completed During Report Period
  - D. Contractual Support Requirements
- 11. General Information
  - A. Test and Evaluation Programs in Progress
  - B. Test and Evaluation Program Status
  - C. Doctrine and Policy Change Recommendation
  - D. Publications and Manuals
  - E. Other
    - (2) Area System
      - (a) Telephone Calls
        - 1. Total for reporting period by precedence
        - 2. Percent change from last period by precedence
        - 3. Grade of service
        - 4. Average holding time
        - 5. Problem analysis
        - 6. Qualitative evaluation statement
      - (b) Teletypewriter Messages
        - 1. Total for reporting period by precedence
        - 2. Percent change from last period by precedence

---

**Figure C-1 (Cont)**

3. Speed of service
  4. Problem analysis
  5. Qualitative evaluation statement
- (c) Data Cards
1. Total for reporting period by precedence
  2. Percent change from last period by precedence
  3. Speed of service
  4. Problem analysis
  5. Qualitative evaluation statement
- (d) Other
1. FAX
  2. Closed circuit TV
  3. Messenger/courier
- B. Special Systems Problems**
- (1) System Security
  - (2) Radio Frequency Interference
  - (3) System Interface
  - (4) Allied/Indigenous Considerations
- C. Procedural Problems**
- (1) Doctrinal Changes
  - (2) Standing Operating Procedure Changes
- D. Frequencies**
- (1) New Requirements
  - (2) Excess Requirements
  - (3) Management
  - (4) Problem Areas

---

**Figure C-1 (Cont)**



### **C-3. C-E Trouble Record (DA FORM 4617-R)**

DA Form 4617-R, C-E Trouble Record, will be reproduced locally on 8" x 10½" paper in accordance with Fig C-2 and C-3. The C-E trouble record should be numbered to enable easy filing and referencing by operators and supervisors. It is prepared by the equipment operator and submitted to the CNCE. The trouble record is prepared as follows and should be kept on file in accordance with unit SOP or AR 340-2.



#### **a. Heading.**

- (1) DTG-Enter the date-time group showing time of record. Use Zulu time unless otherwise directed.
- (2) Record Number-Self-explanatory, chronologically for the current radio day.

#### **b. Blocks.**

- 1-Self-explanatory.
- 2-Self-explanatory.
- 3-Restoration priority.
- 4-Reroute path (if applicable).
- 5-Identify location of trouble, time out, and estimated time of restoration.
- 6-Show suspected or actual RFO. Use RFO codes listed on the reverse side of the form (fig C-3).
- 7-Identify affected equipment and personnel. Use RSC codes (fig C-3).
- 8-Briefly explain corrective action and indicate any assistance required.
- 9-Use to amplify any aspect of the trouble situation.
- 10a-If more than one trouble is encountered, show DTG of first.
- 10b-Show actual restoration.
- 10c-Indicate verified RFO.
- 10d-Show time reported to CNCE(M), CSCE, or other appropriate management element.

- c. The classification of the record will be written or stamped prominently at top and bottom of the record.

C-E Trouble Record FOR USE OF THIS FORM. SEE FM 24 22 PROponent AGENCY IS HQ TRADOC		DTG 181710Z MAY 77	REPORT NUMBER 18-7
1. STATION REPORTING CNCE-7 Site 21		2. PERSON MAKING REPORT a. NAME Sp5 Leather b. PROSIGN RL c. POSITION Shift Spvse	
3. RESTORATION PRIORITY 3C		4. RE-ROUTE PATH NONE AVAILABLE	
5. TROUBLE IDENTIFICATION			
a. SYSTEM NUMBER 21 J1 PAA		TIME OUT 1654 ETR 1800	
b. CIRCUIT NUMBER N/A		TIME OUT ETR	
c. CIRCUIT GROUP NUMBER		TIME OUT ETR	
d. TERMINAL EQUIPMENT CODE		TIME OUT ETR	
6. REASON FOR OUTAGE (RFO)			
a. INITIAL RFO AAQ			
b. EXPLANATORY REMARKS: ENEMY ACTION DESTROYED ONE (1) TRC-145 AT 1st Bde Cp AREA.			
7. RESOURCES AFFECTED			
EQUIPMENT		646	
TRC-145		10th S. 9 200 Co	
NOMENCLATURE		UNIT	
31 M		1	
GRADE/MOS		QUANTITY	
PERSONNEL		d. RESOURCE CODE	
31 M		11	
GRADE/MOS		3	
PERSONNEL		h. RESOURCE CODE	
31 M		463	
GRADE/MOS		QUANTITY	
PERSONNEL		h. RESOURCE CODE	
8. REMEDIAL ACTION TAKEN OR ASSISTANCE REQUIRED REPLACEMENT UNIT DISPATCHED AT 1716Z			
9. REMARKS			
10. ACTUAL TIME OF RESTORATION			
a. INITIAL TROUBLE REPORT DTG 131710Z MAY 77		b. DTG OF RESTORATION 131809Z MAY 77	
c. FINAL RFO AAQ		d. TIME REPORTED 131815Z MAY 77	

DA Form 4617-R  
1 JUN 77

Figure C-2. C-E Trouble Record

**REASON FOR OUTAGE CODE**

Listed below are the most used codes. A more complete listing of RFO codes is found in DCAC 310-55-1, Volume II.

First Character Location of Outage Code		Second and Third Characters Cause of Outage Code	
Code Letters	Meaning	Code Letters	Meaning
A	Distant End User Term	EU	RF Amplifier
B	TROPO Path Propagation	EV	Telegraphic Multiplex
C	Commercial Leased Facility	EW	VF Multiplex
D	Distant End	EZ	Transmitter
E	Local CNCE(T)	FC	Frequency Change
F	Non-Mil US Sta./FAC	GA	Tropo Scatter System
G	Nonreporting Mil Sta	GB	VHF Radio System
H	Interisle Facility	GC	Microwave Radio Sys
I	Interface US Mil System	GD	HF Radio System
J	Intermediate CNCE(T)	GE	UHF Radio System
K	Military Relay Site	GF	SHF Radio System
L	Local Satellite Terminal	JA	High Noise Level
M	Distant End Sat Terminal	JB	High Signal Level
N	Unknown Location	JC	Low Signal Level
O	Airborne User Term (Radio)	JD	Signal Loss
P	Path (Radio)	JE	Manmade Interference
Q	Satellite	KF	Signal Distortion
R	Local Rcvr Site (Radio)	KG	Signal Fade
S	Complete Local Sta./Fac	KH	Frequency Shift/Drift
T	Local Xmitr Site (Radio)	KJ	Natural Interference
U	Local User Terminal	LK	Limited Bandwidth
V	Commercial-Foreign Sta./FAC	LM	Reduced Channel OP
W	Path (Wire/Cable)	ME	Engineering*
X	Interface Allied Mil Sta./Fac	MM	Modification*
Y	Interface Allied Mil System	MP	Preventive Maint
Z	Unidentified (Initial Report Only)	MQ	Installation
		SH	Satellite Receiver*
		SH	Satellite Tracking*

**RESOURCE STATUS CODE (RSC)**

First Character Condition		Second Character Cause		Third Character Operational Impact	
1. Activation	1. Telecom Svc Order	5. Deactivation	5. Enemy Action*	5. Movement Required*	5. Complete Loss of Service
2. Reduced Operations*	2. Equipment Damaged	6. Insufficient Equipment*	6. Personnel Casualty	6. Restoration Required	6. Frequencies Released
3. Inoperable Facilities	3. Equipment Failure	7. Improper Equipment	7. Weather	7. Frequencies Required	7. Complete Loss of Service
4. Insufficient Personnel	4. Equipment Destroyed	8. Reduced Service (MOS & NO)*	8. Personnel Error*	8. Frequencies Released	8. Complete Loss of Service
Asterisk Codes (*) must be explained in paragraph 8.		9. Reserve Resources Used (Type & No)*	9. Frequency Change*	9. Complete Loss of Service	9. Complete Loss of Service
		0. Other*	0. Other*	0. Other*	0. Other*

**Figure C-3. Reverse Side of C-E Trouble Record (RFO and RSC Codes)**

#### **C-4. Operational Resource Record (DA FORM 4618-R)**

a. DA Form 4618-R, Operational Resource Record, will be reproduced locally on 8" x 10½" paper in accordance with Fig C-4 and C-5. The operational resource record (ORR) is submitted by a communications node and distributed to appropriate C-EMS elements. The purpose of the ORR is to provide an up-to-date status report on the extent of C-E resources committed, the capability available, and remaining available resources for planning and restoration of service purposes.

b. The operational resources record is originated at company level and, after approval by the company commander, is passed to the CNCE(M). At the same time, the record is sent to battalion headquarters through command channels. At battalion headquarters, the record is reviewed and, after approval by the battalion commander, is passed to the CNCE(M) and CSCE at battalion level and, simultaneously, through channels to brigade and group. It is subject to review and approval at these levels and is then forwarded to the next higher CSCE. The senior signal unit puts the information in its data base which is made available to the major command C-E staff. When a signal group is part of a theater army communications command, the information is passed through command channels to TACCOM headquarters and made available to the CSPE of the theater army C-E staff. The records may be consolidated at each successive command level or passed in their original form through channels for review and approval.

c. The ORR record format is shown in figure C-4. Boxes 1 through 4 provide information for a message heading. The main body of the record is divided into two parts; the team status and critical shortages. The composition of the various teams to be recorded on are shown in figure C-5. The alphanumeric code for the team is shown along with the normal authorization by type of signal equipment, power units, vehicle, and personnel. Teams are categorized as committed, available, or incomplete. "Committed" means in use, "available" means operational but uncommitted, and "incomplete" means the team is lacking an essential equipment item or team member and thus has a reduced capability. It is intended that the readiness of a team be a command decision. If, for instance, the commander believes a team can perform with acceptable efficiency with less than the full complement of authorized personnel, the team should be categorized "available," with the missing key personnel shown under personnel shortages. The incomplete team category should be used when the operational equipment and qualified personnel are not available to the extent that the team is deemed to be incapable of effective performance. The teams are grouped by type of function for easy reference. In box 5, team codes are listed in column A with their status indicated by numbers in columns B, C, and D. Box 6, Critical Shortages, refers to the major equipment items or personnel requirements needed to convert the incomplete teams to an operational status.



Operational Resource Record		DTG	REPORT NUMBER		
FOR USE OF THIS FORM SEE FM 24 22 PROponent AGENCY IS HQ TRADOC		140001Z MAY 77	14		
1. TO: CSE 10th Sig Bn, 10th Inf Div		2. FROM: CO, FWD COMM CO 10th Sig Bn			
3. PRECEDENCE Priority		4. SECURITY CLASSIFICATION CONF			
5. TEAM STATUS					
a. TEAM CODE	b. NO. COMMITTED	c. NO. AVAILABLE	d. NO. INCOMPLETE		
RT 145 PP 076 MS 029 SC 030 RA 142 RW 049	9 3 3 3 6 2		1		
6. CRITICAL SHORTAGES (Refers to incomplete teams and separate resources)					
a. EQUIPMENT					
(1) TEAM CODE	(2) NOMENCLATURE	(3) QUANTITY	(4) REMEDIAL ACTION TAKEN		
RW 049	AN/GSA-7		MAINTENANCE PARTS		
b. PERSONNEL					
(1) TEAM CODE	(2) MOS TITLE	(3) GRADE	(4) QUANTITY	(5) MOS	(6) REMEDIAL ACTION TAKEN
RW 049	RDO OP	E-3	2	05E20	REPLACEMENTS REQUESTED
NAME & TITLE OF PERSON REPORTING				SIGNATURE	
LARRY SIMPSON, CPT, CMDC				Larry Simpson	

DA Form 4618-R  
1 JUN 77

Figure C-4. Operational Resources Record

### Codes and Composition of Technical Teams

Team Type	Equipment Nomenclature	Team Code	No. of Per.	Major Signal Components	Vehicle	
AUTOMATIC SWITCH	AN TTC-25 (V1)	AS 251	7	AN TTC-25 (300)	2 1 2 T	
	AN TTC-25 (V2)	AS 252	7	AN TTC-25 (600)	2 1 2 T	
	AN TTC-38 (V1)	AS 381	7	AN TTC-38 (300)	2 1 2 T	
	AN TTC-38 (V2)	AS 382	7	AN TTC-38 (600)	2 1 2 T	
	AN TTC-41 (V1)	AS 383		SB-3614 TT	5 4 T	
	AN TTC-41 (V2)	AS 384		SB-3614 TT	5 4 T	
CABLE CONSTRUCTION	AN TTC-41 (V3)	AS 385		SB-3614 TT	1 4 T R	
	Spiral 4	CC 027	12	3 Mi WF-8 G.(CX-11230 G)	3 4 T & 2 1/2 T	
MANUAL SWITCH	Field Wire	CC 017	8	6 Mi WD-1 TT, WF-16 U	3 4 T & 2 1/2 T	
	AN MTC-1	MS 001	3	AN MTC-1 (220)	2-2 1 2 T	
	AN MTC-7	MS 007	1	AN MTC-7 (60)	3 4 T	
	AN MTC-9	MS 009	9	AN MTC-9 (660)	2 Vans	
	AN TTC-35 (V1)	MS 351	1	AN TTC-35 (V1)(50)	1 1 4 T	
MULTIPLEXER	AN TTC-35 (V2)	MS 352	2	AN TTC-35 (V2)(100)	1 1 4 T	
	AN MCC-3	MU 003	3	1 - AN TCC-8	3 4 T	
	AN MCC-6	MU 006	3	2 - AN TCC-4, 1 - AN TCC-7, 1 - AN TCC-50	2 1 2 T	
	AN TCC-69	MU 060	3	2 - TD-352	3 4 T	
	AN TCC-61	MU 061	3	8 - TD-352	2 1 2 T	
	AN TCC-62	MU 062	3	2 - TD-353	2 1 2 T	
	AN TCC-65	MU 065	3	4 - TD-660	1 1 4 T	
	AN TCC-69	MU 069	3	2 - TD-352	1 1 4 T	
	AN TCC-72	MU 072	3	2 - TD-660	1 4 T	
	AN TCC-73	MU 073	3	2 - TD-976, 8 - TD-660	2 1 2 T	
	RADIO REPEATER SET	AN MRC-54	RR 054	3	3 - AN TRC-24	2 1 2 T
		AN MRC-103	RR 103	3	3 - AN GRC-50	2 1 2 T
		AN TRC-109	RR 109	3	2 - AN GRC-50	3 4 T
		AN TRC-110	RR 110	3	3 - AN GRC-50	2 1 2 T
		AN TRC-111	RR 111	3	1 - AN GRC-147	2 1 2 T
AN TRC-113		RR 113	3	3 - AN GRC-103	1 4 T	
AN TRC-138		RR 138	3	3 - AN GRC-144	2 1 2 T	
AN TRC-152		RR 152	3	3 - AN GRC-50	2 1 2 T	
RADIO TELETYPEWRITER	AN GRC-122	RA 122	4	AN GRC-122	3 4 T	
	AN GRC-142	RA 142	3	AN GRC-142	3 4 T	
	AN GRC-26D	RA 026	3	AN GRC-26D	2 1 2 T	
RADIO TERMINAL SET	AN MRC-68	RT 068	3	3 - AN GRC-10, 2 - AN TCC-3	3 4 T	
	AN MRC-69	RT 069	3	2 - AN TRC-24, 1 - AN TCC-7, 1 - AN TCC-50	2 1 2 T	
	AN MRC-73	RT 073	3	1 - AN TRC-24, 1 - AN TCC-7, 1 - AN TCC-20	2 1 2 T	
	AN MRC-102	RT 102	3	2 - AN GRC-50, 1 - AN TCC-7, 1 - AN TCC-7, 1 - AN TCC-20	2 1 2 T	
	AN TRC-108	RT 108	3	1 - AN GRC-50, 1 - TD 352	3 4 T	
	AN MRC-115	RT 115	3	2 - AN GRC-103, 2 - TD 660	1 1 4 T	
	AN TRC-117	RT 117	3	2 - AN GRC-50, 2 - TD 352	2 1 2 T	
	AN MRC-126	RT 126	3	1 - AN GRC-103, 1 - TD 660	1 1 4 T	
	AN MRC-127	RT 127	3	2 - AN GRC-103, 2 - TD 660	1 1 4 T	
	AN TRC-145	RT 145	3	2 - AN GRC-103, 2 - TD 660	1 1 4 T	
	AN TRC-151	RT 151	3	2 - AN GRC-50, 2 - TD 660	2 1 2 T	
	SIGNAL CENTER	AN MGC-9	SC 009	4	AN VRC-49, AN GSA-7	1 4 T
		AN MGC-17	SC 017	4	2 SB-86 TTY	2 1 2 T
		AN MGC-19	SC 019	8	2 TTY Terminals	3 4 T
		AN MGC-22	SC 022	8	10 TTY Terminals	2 1 2 T
AN MGC-23		SC 023	8	8 TTY Terminals	5 T	
AN MSC-29		SC 029	12	16 TTY Relay	5 T	
AN MSC-58		SC 058	10	12 TTY Terminals	2 1 2 T	
AN TSC-76		PP 076	3	12 TTY Terminals	2 1 2 T	
CNCE	SB-611/MRC	PP 611	4	1162 2 Wire Ckts	3 4 T	
	SB-675/MSC	PP 675	4	1162 2 Wire Ckts	3 4 T	
	AN TSQ-84	PP 084	3	954 2 Wire Ckts	2 1 2 T	
	AN TSQ-85	PP 085	4	972 4 Wire Ckts	2 1 2 T	
	AN TRC-112	TS 112	3	4 TD-976	2 1 2 T	
TROPO TERMINAL	AN TRC-121	TS 121	3	1 - AN GRC-143	2-1 1 4 T	
				2 - AN GRC-143	2-2 1 2 T	

Figure C-5. Reverse of Operational Resources Record (Codes and Composition of Technical Teams)

## C-5. Traffic Status Record (DA FORM 4619-R)

a. DA Form 4619-R, Traffic Status Record, will be reproduced locally on 8" x 10½" paper in accordance with Fig C-6. The traffic status record is prepared on a periodic basis (usually daily) by the CNCE(M) based on information provided by both the telephone switch and the telecommunications center and is normally sent to the controlling CSCE for traffic engineering.



b. The traffic status record data is used—

- (1) To verify previously stated communications requirements.
- (2) To react to changes in force structure or the tactical situation.
- (3) For optimizing the communications system remaining after damage occurs.
- (4) To predict future changes to the system by observing trends.
- (5) To justify equipment and personnel needs.

**Note:** With the introduction of automatic switches, timely and accurate reporting will be essential to the centralized management aspects of reprogramming switches to rebalance or reconstitute degraded portions of the communications system.

c. A sample record is shown in figure C-6 and is explained below.



- (1) Boxes 1 through 4 provide information for a message heading.
- (2) Box 5 lists the time covered by the record period (use DTG for both “to” and “from”).
- (3) The record is divided into four principal areas: total voice traffic, voice traffic by trunk group, total message/data traffic relay and terminal, and traffic moved by messenger.
- (4) Boxes 6 and 7 are structured to conform with the output of the AN/TTC-38. The data for box 8 can be collected at the relay for manual tape relay operation. Data for boxes 9 and 10 are provided by the telecommunications center record section.



Traffic Status Record				DTG:		
FOR USE OF THIS FORM SEE FM 24 22 PROPOSED AGENCY IS HQ TRADOC				170800Z MAY 77		
1. TO: <b>CSCG (VI) VIA COEPS</b>			2. FROM: <b>CSCG (PI) 8th INF DIV</b>			
3. PRECEDENCE: <b>PRIORITY</b>			4. SECURITY CLASSIFICATION: <b>CONF</b>			
5. PERIOD OF REPORT: FROM: (DTG) <b>160001Z MAY 77</b> TO: (DTG) <b>162400Z MAY 77</b>						
6. TOTAL TRAFFIC FOR PERIOD: (Automatic Switch Data Only)						
		(1) ROUTINE	(2) PRIORITY	(3) IMMEDIATE	(4) FLASH	(5) FLASH OR
a. NARROWBAND-VOICE/ SECURE		1680	100	15	20	5
b. NARROWBAND-TT-DATA/ SECURE						
c. WIDEBAND		32	14	12	2	1
	TOTAL				ATTEMPTS	COMPLETIONS
d. CALLS CLASSMARKED FOR MANUAL SERVICE		15	h. OPERATOR CALLS		45	39
e. INTERCEPT CALLS		26	i. INFORMATION CALLS		82	82
f. RECALLS		14	j. PROGRESSIVE CONFERENCE CALLS		5	5
g. AVERAGE HOLDING TIME		2M	k. PRE-PROGRAMMED CONFERENCE CALLS		23	23
7. TOTAL CALLS BY TRUNK GROUP:						
<input type="checkbox"/> AUTOMATIC SWITCH <input checked="" type="checkbox"/> MANUAL SWITCH (SELECTIVE PEG COUNTS)						
a. TRK. GRP. NO.	b. INCOMING	c. OUTGOING PRIMARY ALTERNATE	d. PRESELECTION ATTEMPT COMPLETION	e. CALLS LOST PRIMARY ALTERNATE	f. MAINT.	g. LOCKOUT
033	632	764 (74)	4	2	1	1
8. TOTAL MESSAGE/CARDS BY TRUNK GROUP (RELAY)						
a. TRUNK GROUP #	b. OUTGOING	c. INCOMING	d. BACKLOGGED			
006	25	32	0			
9. TOTAL MESSAGE/CARDS (TERMINAL)						
FUNCTION	TYPE	1 ROUTINE	2 PRIORITY	3 IMMED.	4 FLASH	
a. TRANSMITTED	MSG/CARD	32/9	14/4	8/0	1/0	
b. RECEIVED	MSG/CARD	66/6	19/2	9/1	2/0	
c. BACKLOGGED	MSG/CARD	0/0	0/0	0/0	0/0	
d. HANDLING TIME	MSG/CARD	30/19	20/7	12/1	6/0	
e. UNACCOUNTED	MSG/CARD	0/0	0/0	0/0	0/0	
10. MESSENGER SERVICE TOTALS:		a. SCHEDULED: (1) AIR: 8 (2) MOTOR: 6		b. SPECIAL: (1) AIR: 1 (2) MOTOR: 3		

DA Form 4619-R  
1 JUN 77

Figure C-6. Traffic Status Record

## **C-6. Special Communications Authorization Request (DA FORM 4620-R)**

**a.** DA Form 4620R, Special Communications Authorization Request, will be reproduced locally on 8" x 10½" paper in accordance with Fig C-7. A special communications authorization request (SCAR) is submitted when service over and above that prescribed in doctrine/SOP is required by a user. The SCAR should be submitted to the appropriate CNCE(M) which will either provide the service or will forward the request to higher headquarters when it does not have the authority to approve the request.



**b.** The SCAR consists of two principal parts: identification and justification of the user's requirement, and evaluation and decision by the C-EMS elements involved. Boxes 1 through 4 provide information for a message heading.

**c.** The subscriber information called for in boxes 5a through 5f is required to provide the requested service; the information in box 5g is critical to the evaluation and approval processes. The justification should clearly demonstrate why the service prescribed by doctrinal policy does not meet the user operational requirements. The assessment of the communications request (box 6) is prepared by the approval of the supporting signal unit commander. It requires consideration of the resources needed and available, contingency plans, unit priorities, planned force structure changes, and an estimate of possible system implication beyond the local nodal network.

SPECIAL C-E AUTHORIZATION REQUEST		DTG:
FOR USE OF THIS FORM. SEE FM 24 22 PROPOSER AGENCY IS HQ, TRADOC:		131210Z MAY 77
1. TO: CO, Co A 8th Sig BN	2. FROM: S3 1st Bde 8th Inf Div	
3. PRECEDENCE: Immediate	4. SECURITY CLASSIFICATION: CONFIDENTIAL	
5. SUBSCRIBER INFORMATION: (To Be Completed by Requester)		
a. ORGANIZATION: Hq, 1st Bde, 8th Inf Div	b. LOCATION: (Coordinates) LG 17599488	
c. DATE OF REQUEST: 13 MAY 77	d. DATE NEW SERVICE REQUIRED: 18 MAY 77	
e. CURRENT COMMUNICATION SERVICE (In Addition to Organic TOE) PROVIDED:		
(1) TRUNKS: VOICE <u>3</u> TELETYPEWRITER <u>1</u> DATA <u>0</u>		
(2) SUBSCRIBER: LOCAL LINES <u>24</u> EXTENSIONS <u>8</u>		
(3) PREFERENTIAL SERVICES: SPECIFY <u>N/A</u>		
(4) DEDICATED CIRCUITS: <u>3</u>		
(5) RWI CALL SIGN <u>RED ROOSTER</u>		
(6) SPECIAL TERMINAL EQUIPMENT AUTHORIZED ABOVE DOCTRINE: <u>N/A</u>		
f. ADDITIONAL COMMUNICATION SERVICE REQUESTED: ONE DEDICATED VOICE CIRCUIT FOR TASE (S2-3 A10)		
g. JUSTIFICATION: THE SERVICE IS NEEDED TO SUPPORT TRAFFIC LOAD GENERATED BY THE ATTACHED TASE TEAM FROM 18 MAY 77 TO 26 MAY 1977		
6. ASSESSMENT OF SCAR (For Nodal Authority Use)		
a. ADDITIONAL RESOURCES OR FACILITIES REQUIRED:		
b. AVAILABILITY OF REQUIRED RESOURCES/FACILITIES: NONE AVAILABLE, SERVICE MUST USE EXISTING RESOURCES		
c. ADDITIONAL CONSIDERATIONS: 1 COMMON USER VOICE CHANNEL WOULD BE PRE-EMPTED IF THIS REQUEST IS IMPLEMENTED.		
d. ACTION RECOMMENDED: PRE-EMPTING A CU CHANNEL WOULD DEGRADE OVER ALL SYSTEM, RECOMMEND ASSIGNMENT OF A "PRIORITY" CLASS MARK TO THE TASE TEAM FOR REQUIRED PERIOD.		
e. APPROVAL/DISAPPROVAL: APPROVED FOR ACTION OUTLINED IN ITEM 6 D.	SIGNATURE George Brown Capt, Eads	

DA Form 4620-R  
1 JUN 77

Figure C-7. Special Communications Authorization Request

## **C-7. Telecommunications Service Order (DA FORM 4621-R)**

**a.** DA Form 4621-R, Telecommunications Service Order, will be reproduced locally on 8" x 10½" paper in accordance with Fig C-8. The telecommunications service order (TSO) is a technical directive that is issued to a subordinate facility or operating command (e.g., elements of the CSCE at any level, the C-E staff of a major command, the unit staff of a signal unit, or the CNCE of a node). All TSO's in a tactical situation will be classified CONFIDENTIAL or higher.



**b.** The purpose of the TSO is to direct the performance of an individual task or groups of tasks for the implementation of signal orders, signal annexes to command operations orders, restoration of service in response to trouble reports, approved special communications authorization requests, or SOP doctrinal communications entitlements. The TSO form is structured to direct the installation and operation of all types of communications systems under a wide variety of situations. It is designed to be transmitted by secure electronic means from higher authority to the operating signal units.

**c.** The informational content of each block on the TSO form is described below. A sample format for an electrically transmitted TSO is shown in figure C-9.

Box 1. Enter the unit name and address of the C-EMS facility which directs the action ordered by the TSO. Include site designator if required.

Box 2. Enter the unit name and address of the C-EMS facility to which the TSO is directed for action. Routing designators will be added when the TSO is to be sent over common-user facilities. Include site designator if required.

Box 3. Enter the unit name and address of the C-EMS facility to which "information only" copies of the TSO are to be sent. Include site designator if required.

Box 4. Designate the security classification for the information in the TSO: Unclassified, Confidential, Secret, Top Secret.

Box 5. Designate the TSO precedence for transmission: Routine, Priority, Immediate, Flash, Flash Override.

Box 6. Identify the TSO number and DTG of issue.

Box 7. Identify the source document from which the implementation instructions contained in the TSO were derived. The source document may be a signal order, another TSO, other technical directives, or verbal orders from the commander.

(Continues on page C-22)

# Telecommunications Service Order

FOR USE OF THIS FORM SEE FM 24 22  
PROPOSER AGENCY IS HQ. TRADOC

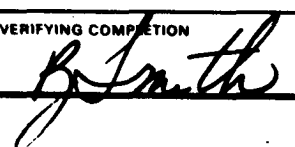
<b>1. TO:</b> CNCE 2 <sup>D</sup> Inf Bde	<b>2. FROM:</b> CSC E 52 <sup>D</sup> Mech Div
<b>3. INFO:</b> C-E OFF (OPS) 2 <sup>D</sup> Inf Bde	<b>4. SECURITY CLASSIFICATION:</b> CONFIDENTIAL
<b>5. PRECEDENCE:</b> ROUTINE	
<b>6. TSO NUMBER:</b> 3-24	<b>DTG:</b> 200830Z MAY 77
<b>7. REFERENCE</b> a. HEADQUARTERS: OPORD 12/52 <sup>D</sup> MECH DIV b. DTG: 190800Z MAY 77 c. SUBJECT: Bde Jump	
<b>8. SYSTEM / CIRCUIT INFORMATION:</b> a. ACTION REQUIRED: <input type="checkbox"/> ACTIVATE <input type="checkbox"/> DEACTIVATE <input type="checkbox"/> REROUTE <input checked="" type="checkbox"/> MODIFY b. REQUIRED COMPLETION DTG: 220600Z MAY 77 c. RESTORATION PRIORITY: 3C d. STATION / FACILITY DESIGNATOR: KN e. SYSTEM / CIRCUIT DESIGNATOR: KN KE PAA f. ROUTING INSTRUCTIONS: NA g. OPER IDENTIFICATION: 2 <sup>D</sup> Bde h. INTERFACE: N/A i. WIRE / CABLE (1) TYPE: NA (2) TERM A LOC: NA (3) TERM B LOC: NA j. RADIO SYSTEMS: (1) TERM A LOC: SAME (a) ANTENNA: AZ 05° HT 45 FT (RT) HQR (L) FREQUENCY: SAME (R) CALL SIGN: SAME (2) TERM B LOC: 6B 325588 (a) ANTENNA: AZ 185° HT 45 FT (RT) HQR (L) FREQUENCY: SAME (R) CALL SIGN: SAME (3) RELAY: LOC: CALL SIGN: (a) ANT AZ: HT: PLN: FREQ: S: R: (b) ANT AZ: HT: PLN: FREQ: S: R:	
<b>9. EQUIPMENT INFORMATION:</b> a. ACTION REQUIRED: <input type="checkbox"/> INSTALL <input type="checkbox"/> REMOVE <input type="checkbox"/> MODIFY <input type="checkbox"/> REPAIR REPLACE <input checked="" type="checkbox"/> OTHER: RELOCATE b. TYPE / MODEL NUMBER: TRC-145 c. QUANTITY: 1 d. LOCATION: 6B 325588	
<b>10. REMARKS:</b> (Use back of form if necessary)	
<b>DTG COMPLETED AND REPORTED</b> 220510Z MAY 77 / 220530Z MAY 77	<b>PERSON VERIFYING COMPLETION</b> 

DA Form 4621-R  
1 JUN 77

Figure C-8. Telecommunications Service Order



Box 8A. Check off the type of action which the TSO directs. The action checked will be transmitted.

Box 8B. Enter the DTG which is the deadline for completing the action.

Box 8C. Enter the restoration priority for the action desired.

Box 8D. Enter the designator of the station or facility affected by the TSO.

Box 8E. Using the standard numbering procedures, enter the designator of the system or circuit affected by the TSO.

Box 8F. Enter the routing instructions applicable to the action directed. This will include any patching instructions.

Box 8G. Identify the using organization if the system/circuit is specifically assigned.

Box 8H. Identify interface requirements such as with cable or commercial systems.

Box 8I. Enter any types of conditioning equipment required.

Box 8J. Enter the (1) type of wire or cable directed, (2) unit name, and/or (3) coordinates of terminal of wire/cable system/circuit.

Box 8K. These entries are appropriate to the multichannel communications systems. A system or link will require entries in (1) and (2) and may require multiple entries at (3) corresponding to the number of relays required. The entries in items (1) and (2) are coordinates describing the location of terminal A and/or terminal B; the antenna azimuth (AZ), height (HT), and polarization (PLRZ); and send (S) and receive (R) frequencies and the station call sign. For each of the relays (3), enter the relay site number, coordinates of the location, and the call sign of the relay station. For each leg, the send (S) and receive (R) frequency will be identified along with the antenna azimuth (AZ), height (HT), and polarization (PLRZ) on that leg.

Box 9A. Check off the applicable type of equipment action. The action will be transmitted together with—

Box 9B—equipment type/model identification code (TD-660, AN/TRC-138, etc.),

Box 9C—quantity of each type, and

Box 9D—location at which the equipment action is required.

Box 10 will contain additional information amplifying instructions as appropriate (use back of form if necessary). The block indicating completion and reporting of the action will be completed and the verification block signed.

1. CSCE, 52D MECH DIV
2. CNCE (KN), 2D SIG BDE
3. C-E OFF, 2D BDE
4. CONFIDENTIAL (Listed for training only—message is unclassified)
5. Routine
6. 3-24/200830Z MAY 76
7. A-OPORD 12/52D MECH DIV  
B-190800Z MAY 76  
C-BDE JUMP
8. A-MODIFY  
B-220600Z MAY 76  
C-3C  
D-KN  
E-SYSTEM KNKFPAA  
F-NA  
G-2D BDE  
H-NA  
I-NA  
J-NA  
K-(1) NC  
    (A) AZ 05/HT 45/PLRZ H  
    (B) NC  
    (C) NC  
    (2) EB325588  
        (A) AZ 185/HT 45/PLRZ H  
        (B) NC  
        (C) NC  
    (3) NA  
        (A) NA  
        (B) NA
9. A-OTHER/RELOCATE  
B-AN/TRC-145  
C-1  
D-EB325588
10. MULTICHANNEL SYSTEM WILL CONTINUE UNDER OP CONT OF 2D BDE  
(NOTE: Item 10 may be expanded as needed.)

---

**Figure C-9.** Message format for electrically transmitted TSO

## **C-8. Communications System Document Change Order (DA FORM 4622-R)**

**a.** DA Form 4622-R, Communications System Document Change Order, will be reproduced locally on 8" x 10½" paper in accordance with Fig C-10. The communications system document change order is prepared and issued by a C-E staff section, a signal unit staff, or a CSCE or CNCE(M). Its purpose is to disseminate changes to any record document to appropriate subordinate units and C-EMS facilities. The change order becomes a part of the basic document file and is retained for as long as the basic file.



**b.** The change order is issued as a result of changes to the C-E annex of a command operations order to the C-E operations order of a signal unit; to command or unit SOP, and changes to any technical directive where the change is minor and does not require reissue of the complete document. The change is particularly useful for making minor modifications on circuit, traffic, and other diagrams.

**c.** Complete the change order (fig C-10) as follows:

Box 1. Identify the C-EMS element that is issuing the change order.

Box 2. Enter the same unit addresses that were designated as action addresses on the document being changed.

Box 3. Enter the same unit addresses that were designated as information addresses on the document being changed.

Box 4. Enter the security classification of the information being transmitted by the communications system document change order.

Box 5. Enter the precedence required by the information contained in the communications system document change order.

Box 6. Communications system document change orders will be serially numbered and this box will contain an entry that will identify the change order.

Box 7. Enter the DTG at which the change is to be made effective.

Box 8. Completely identify the basic communications system document that is to be changed by the change order.

Box 9. Entries here will include a reference locating the part of the document to be changed as well as the actual change. Block A provides space for citing the part of the document to be deleted and block B provides space for additions to the document.



C-E System Document Change Order		DTG:
FOR USE OF THIS FORM SEE FM 24 22 PROponent AGENCY IS HQ TRADOC:		161430Z MAY 77
1. TO:	FROM:	
OIC, FASC (21) OIC, FASC (22) OIC, FASC (23)	CSCE 10 <sup>th</sup> Sig BN	
3. INFO:	4. SECURITY CLASSIFICATION:	
OIC, 10 <sup>th</sup> Inf DISCOM ATTN: C-E	CONF	
	5. PRECEDENCE:	
	ROUTINE	
6. CHANGE ORDER NUMBER:		
14-18		
7. EFFECTIVE DTG OF CHANGE:		
UPON RECEIPT		
8. REFERENCE DOCUMENT:		
a. TITLE	b. NUMBER	c. DTG
10 <sup>th</sup> Inf Div TELEPHONE TRAFFIC DIAGRAM	APP4(C-E) ANNEX C to ORD 18	10 MAY 77 EFFECTIVE 100900Z MAY 77
9. NARRATIVE DESCRIPTION OF CHANGE:		
a. DELETION: NONE		
b. ADDITION: ADD ONE(1) COMMON USER TRUNK CIRCUIT FROM DISCOM (46) TO EACH FASC		
AUTHORIZED BY: NAME, TITLE		SIGNATURE
POLL, LTC, C-E		<i>[Signature]</i>

DA Form 4622-R  
1 JUN 77

Figure C-10. Communications System Document Change Order

## **C-9. Master Station Log**

**a.** The master station log (fig C-11) file is maintained at each facility and is a chronological history of all significant events. Shift supervisors jointly review the log at change of shift for completeness and accuracy of the entries. The facility supervisor may review the form and sign it to indicate acceptability prior to filing.

**b.** The ACTION/EVENT column is used to—

(1) Briefly describe the event.

(2) Record shift changes including the names of personnel coming on duty.

(3) Record the status of circuits at change of shift. This insures that shift supervisors are aware of the status of any circuit troubles or outages and the remedial actions taken or required.

**c.** For entries not directly related to circuits, leave the CHANNEL OR CIRCUIT column blank and enter information (e.g., generator failure, staff visit, etc.) in the ACTION/EVENT column.

MASTER STATION LOG			FACILITY	DATE	PAGE	
CHANNEL OR CIRCUIT	ZULU TIME	OP INIT	TIME PERIOD			
			FROM		TO	
			ACTION/EVENT			
Unclassified example only						

32D2-MSL-DIA(I)  
(DD 1753)

SUPERSEDES 32A1-FXSIA-DIA(I) ESC -983-66

111SA-FM 625-73

Figure C-11. Master Station Log (DD Form 1753)

## C-10. System and Circuit Status Record (DA FORM 4623-R)

a. DA Form 4623-R, System and Circuit Status Record, (cards 1 and 2, front and back) will be reproduced locally on 8" x 10" card stock paper in accordance with Fig C-12, C-13 and C-14. The system and circuit status record is maintained by circuit controllers in the CNCE(T). It provides detailed, current-status information on all terminating and patched-through systems and circuits. The record is designed to contain the information required on both systems and circuits as well as groups of circuits.

**Note:** This record and the system and circuit status record-system channel allocation (covered in the next paragraph) are temporary files maintained at the CNCE(T) during the time that each circuit is active. The information entered on the records is obtained from TSO's received by the CNCE(T) and from the results of testing and monitoring by the CNCE(T). The term "system" as used here denotes a radio multichannel or cable link between two communication nodes.

b. Front of status record, card 1 (fig C-12).

Box 1. Enter the number that will identify the system or circuit in accordance with the prescribed system/circuit numbering system.

Box 2. This box will contain two entries for both systems and circuits. These two entries will designate the terminal nodes of the system/circuit. The node entered first is to be the controlling node.

Box 3. For system records, identify the type of system; e.g., radio, wire, cable. For circuit records, identify the communications node utilizing the circuit; e.g., voice, TTY, voice/TTY, data, fax, etc.

Box 4. Identify the signal unit at which the controlling CSCE is assigned.

Box 5. Enter the restoration priority in accordance with prescribed priority procedures.

Box 6. Identify the authority, technical service order, VOCO, other/directives, and the DTG authorizing the activation of the system/circuit.

Box 7. Identify the DTG on which the system/circuit was activated.

Box 8. For system records, this box will contain an entry only when the system goes to a single user. The entry will identify the user. The box will be left blank when the system serves multiple users. For circuit records, this entry will identify either the user to whom the circuit is assigned or the terminating signal facility.

Box 9. Identify the transmission equipment, video patch equipment (as appropriate), and multiplexer which is associated with the system at the node. This entry will be completed for both system and circuit records.

Box 10. Identify the type of switchboards, teletypewriter relay, other equipment (instruments), or communications facilities which utilize the circuit. For system records, this box will be left blank unless all the circuits in the entire system are terminated in the same type equipment.

Box 11. Identify the activity responsible for the equipment/facilities shown in box 10 together with the telephone number at which they can be contacted.



SYSTEM AND CIRCUIT STATUS RECORD									
1. SYSTEM / CIRCUIT NO.			2. TERMINAL - FROM TO			3. TYPE	4. CONTROL CSCE		5. RP
6. TSO / AUTHORITY NO. DTG			7. DTG ACTIVATED			8. USER - TITLE			
9. SYSTEM TERMINAL EQUIPMENT			10. CIRCUIT TERMINAL EQUIPMENT			11. USER CONTACT TEL. NO.			
12. SYSTEM INTERFACE EQUIPMENT			13. CIRCUIT INTERFACE EQUIPMENT			14. CIRCUIT CONDITIONING EQUIPMENT			
ANALOG / DIGITAL CONVERTER		DC TELEGRAPH LINE CONVERTOR		AMPLITUDE EQUALIZER					
ASYNCHRONOUS DIG COMBINER		IMPEDANCE MATCHING		ATTENUATOR					
CRYPTOGRAPHIC UNIT		MODEM RATE		DELAY EQUALIZER					
DATA BUFFER		SIGNALLING CONVERTER		ECHO SUPPRESSOR					
DIGITAL MULTIPLEXER		OTHER:		LINE AMPLIFIER					
VF MULTIPLIER				PAD					
OTHER:				REGENERATIVE REPEATER					
				RELAY COIL					
				OTHER:					
15. ROUTING									
16. SYSTEM TERMINATION IDENTIFICATION SYSTEM NO.						17. CIRCUIT PANEL APPEARANCE			
GROUP	DESIGNATOR	CH	GROUP	DESIGNATOR	CH	IN	OUT		
1			5						
2			6						
3			7						
4			8						
1. SYSTEM / CIRCUIT NO.			2. TERMINAL - FROM TO			3. TYPE	4. CONTROL CSCE		5. RP

DA Form 4623-R  
1 JUN 77

INSTRUCTIONS FOR USE OF THIS FORM ARE IN APP B, FM 24-22

Figure C-12. Front of System and Circuit Status Record, Card 1

Box 12. For system records, identify the type of equipment. If multiple entries would be required for any type of item, the presence of the item will be indicated by a checkmark. For circuit records, identify the type equipment used on that circuit at that node.

Box 13. For system records, the boxes will not be used. For circuit records, identify the type equipment used on that circuit at that node.

Box 14. For system records, the boxes will not be used. For circuit records, identify the type equipment used on that particular circuit at the node designated.

Box 15. Identify routing of system, circuits, and/or groups as appropriate. System routing identifies multichannel sites, as appropriate.

Box 16. For system records, the cable designation for each 12/24-channel group (26 per cable) will be identified. The column labeled CH will show the number of channels in the group. For circuit records, the group and channel that bring the circuit to the CNCE will be identified. If the circuit is terminated at the node, only one entry is shown. If the circuit is patched through the node, then two entries will be required. The system number will be shown on the heading line and is a cross reference to system channel allocation shown on card 2. For circuit groups patched through the node, two entries will be required showing the groups and the number of channels utilized.

Box 17. Indicate the locations on the patch panel where the circuit is brought IN from the system terminal equipment and is connected OUT to circuit terminal equipment or to a group designated in box 16 for through circuit group patches. Individual circuit entries must be shown for group patches.

c. Rear of status record, card 1 (fig C-13). The entries on this side of the record card are used for system/circuit outages. If the entire system goes down, this outage is recorded on the system record card. If only a single channel goes out, the outage is recorded on the circuit record card.



Box 18. Fill out as follows:

**Block A. DTG OUT.** Identify the DTG at which the system/circuit was discovered as being out.

**Block B. DTG IN.** Identify the DTG at which the system/circuit was restored for service to the user.

**Block C. RFO.** Identify the reason for the system/circuit outage. The entries will use the same RFO codes that are used with the trouble report.

**Block D. ACTION TAKEN.** Describe how the system/circuit trouble was corrected or how the restoration was effected. Examples of these entries would be: transmit frequency changed to eliminate RFI, maintenance personnel replaced module in mux, antenna repaired/replaced, new cable laid to replace destroyed cable from mux to xmtr,

Box 19. This section will be used to record implementation of system/circuit modifications. The entries in the system and circuit status record cards will be made in pencil so that when minor changes occur, the new information can be used to record the box number(s) which were changed, authority will list the TSO number and issuing headquarters and the DTG of the TSO or other order directing the system/circuit modification.

Box 20. This section will be used to record any other pertinent information not shown elsewhere on the card or for amplification of any entries on the record.

18. TROUBLE AND RESTORATION RECORD						
a. DTG OUT		b. DTG IN		c. RFO (CODE)	d. ACTION TAKEN	
19. SYSTEM/ CIRCUIT MODIFICATIONS					20. REMARKS:	
CHANGE	AUTHORITY	DTG	CHANGE	AUTHORITY	DTG	
1			6			
2			7			
3			8			
4			9			
5			10			

DA FORM 4623-R, 1 Jun 77

**Figure C-13.** Rear of System and Circuit Status Record, Card 1

## **C-11. System and Circuit Status Record-System Channel Allocation (Card 2, Front and Back)**

**a.** Both the system allocations and the restoration priority are recorded on this card (fig C-14). One card can be used for 48 channels in increments of 12-channel groups. If a system has 96 channels, two cards are required. This record is completed and filed with the system and circuit status record as explained in the note in the preceding paragraph.



**b.** Boxes 1 through 6. The heading information is printed at the top of one side and the bottom on the other side to allow for use in either a box or flip type file container. The information in the heading is the same as on card one with the addition of an entry, box 6, identifying the number of 12-channel groups in the system.

**c.** The entry under “group” will be made to designate the 12-channel group number.

**d.** The circuit number will be entered on the line opposite the allocated channel and the restoration priority for the individual circuits will be entered on the appropriate line.



1. SYSTEM NO.		2. TERMINAL FROM TO		3. TYPE	4. CONTROLLING CSCE		5. RP	6. GROUP
GROUP	CHAN	CIRCUIT NUMBER		RP	GROUP	CHAN	CIRCUIT NUMBER	
	1							
	2							
	3					3		
	4							
	5					5		
	6					6		
	7							
	8							
	9					9		
	10					10		
	11					11		
	12					12		

**SYSTEM AND CIRCUIT STATUS RECORD -  
SYSTEM CHANNEL ALLOCATION**

SYSTEM AND CIRCUIT STATUS RECORD - SYSTEM CHANNEL ALLOCATION								
GROUP	CHAN	CIRCUIT NUMBER		RP	GROUP	CHAN	CIRCUIT NUMBER	
	1					1		
	2					2		
	3							
	4							
	5					5		
	6					6		
	7							
	8							
	9					9		
	10					10		
	11					11		
	12					12		

1. SYSTEM NO.		2. TERMINAL FROM TO		3. TYPE	4. CONTROLLING CSCE		5. RP	6. GROUP
---------------	--	---------------------	--	---------	---------------------	--	-------	----------

Figure C-14. System and Circuit Status Record, Card 2, Front and Back

## C-12. Circuit Routing List

a. The circuit routing list (fig C-15) is used to provide information for tandem connections and to serve as the basis of instructions to operating units for patching and terminations. The list has the same status as the circuit diagram. The senior signal unit CSCE, upon receipt of the chart, places the information in the automatic database at the CSCE and sends to its appropriate subordinate units that portion(s) of the list for which installation is being assigned. Instructions to implement the list will be sent by the senior signal unit to its subordinate units as a technical service order or other directive.



b. The list provides the CNCE with information regarding the originating and terminating points, the type of service provided, the use of the circuit, and the circuit within the group.

Column 1 of the circuit routing chart numerically lists each channel of the system using two digits (e.g., 01, 02, 03; 13-24; 25-36; etc.).

Column 2 contains the circuit designator based on information from appendix B.

Column 3 contains the priority designator based on information from appendix B.

Column 4 indicates the circuit type taken from appendix B.

Column 5 indicates the specific origin of circuit; e.g., 52d Div S2, III Corps G3, CSPE, etc. A switch may be designated by PR-SL number.

Columns 6 through 9 list the system(s) through which the circuit is patched. Where necessary, more than four systems may be listed. The first entry will be the point of origin and the last entry will be the point of termination. The channel number of the system carrying the circuit is indicated by a two-digit number affixed at the end of the system designator.

Column 10 indicates the settings for the equipment "2-wire/4-wire" and "ringer" (signaling mode) switches. For example, for channel 04 of figure C-15, column 10 (labeled CHAN SETTING) has 4W OFF/2W OFF indicated. Settings on the left of the slash mark (/) are to be used by the controlling terminal (term A), while the settings on the right of the slash mark are for the other end (term B). In the example, terminal 21 will set the equipment's (e.g., CV-1548) 2-wire/4-wire switch to 4W and the signaling mode switch (on panel 18A3, channel 6) to the OFF position. Terminal J1 will set its equipment 2W/4W switch to 2W and its signaling mode switch to OFF.

**Note:** The word ON in column 10 refers to "ringer *on*" (on some equipment) and to the "AC" position of the signaling mode switch of the CV-1548.

Column 11 indicates the specific termination point of the circuit; e.g., S3, CO, TCC, etc.

Column 12 indicates the system designator which identifies the CRC. It also establishes the system priority, which will be the priority of the highest priority circuit excluding the engineering/control channel.

### Circuit Routing List

CH	CIRCUIT	PR	TY	FROM	SYS 1	SYS 2	SYS 3	SYS 4	CHANNEL SETTING	TO
01	421J161	3C	CU	9221	21J1PAA-01				4W OFF/4W OFF	8765
02	10123ZZ	3C	SU	EW	0121PAC-02	21J1PAA-02	23J1CAA-01		4W OFF/4W OFF	EW
03	622J133	4B	SU	S3	2122PAC-01	21J1PAA-03			4W OFF/2W OFF	G3
04	G01J14C	3C	TT	TCC	0121PAA-01	21J1PAA-04			4W OFF/2W ON	MR
05	322J121	4A	CU	9222	2122PAC-02	21J1PAA-05			4W OFF/4W OFF	8765
06	B22J18E	3A	SC	Data	2122PAC-06	21J1PAA-06			4W OFF/4W OFF	TADS
07	421J162	3C	CU	9221	21J1PAA-07				4W OFF/4W OFF	8765
08	G21J11C	3B	TT	MR	21J1PAA-08				4W OFF/4W OFF	MR
09	82123GG	4A	LL	9221	21J1PAA-09	23J1CAA-02			4W OFF/4W OFF	SASP
10	102J1HH	3C	SU	CBRE	0102PAA-01	0122MAA-01	2122PAC-08	21J1PAA-10	4W OFF/2W ON	CBRE
11										
12	121J1CC	1A	SU	CNCE	21J1PA-12				2W ON/2W ON	CNCE

System 21J1PAA  
Priority 3A  
Page 14

**Figure C-15. Circuit Routing List**

# INDEX

Item	Page	Item	Page
ABM Plan	5-17	Data Base	5-8
ACP 119	5-19	DCS Entry	3-5
Automated CEOI	5-18	Deactivation	7-7
Brigade Communications System	3-8	Defense Communications Agency	2-3
CEOI	5-4	Direct Access Capability (DAC)	5-10
C-E Plan	5-3	Directory Service	5-22
C-E Trouble Record	C-2	Division Communication System	5-7
Circuit Designators (numbers)	B-6	Division Level Frequency Management	5-18
Circuit Priority	B-9	ECCM	6-24
Circuit Routing List	6-11	Engineering	6-1
Closures (of systems)	7-7	Network Layout	6-4
Collection of Performance Data	6-22	Traffic Engineering	6-4
Communications Electronics		Responsibilities	6-7
Management System (C-EMS)		Telephone Traffic Engineering	6-7
Definition	1-2	Teletypewriter/Data Traffic Engineering	6-8
Design	1-2	Functions	5-2
Management Policies	2-3	Equipment Compatibility	2-4
Structure	2-4	Forward Edge of Battle Area (FEBA)	3-1
Communications Equipment		Frequency Allocation Branch	5-17
Support Element	2-4	Frequency Allocation and Usage List	5-15
Communications Nodal		Frequency Management Channels	5-15
Control Element	2-4	Implementation and	
CNCE(M)	7-2	Installation, Systems	7-1
Functions	7-2	Intelligence Support	
CNCG(T)	7-3	Command (INSCOM)	5-18, 5-19
Functions	7-3	International Frequency Control	5-14
Communications System		Jamming and Interference	7-5
Document Change Orders	C-24	Joint Frequency Panel (J/FP)	5-17
Communications System		Line of Communications (LOC)	4-3
Control Element	2-4	Line Route Map	6-15
	7-1	Master Station Log	C-26
Communications System		Measures of System Effectiveness	6-22
Information Summary	C-1	Messenger Service	5-21
Communications System		Monitoring	7-1, 7-7
Planning Element	2-4	Multichannel Systems	
COMMZ		and Radio Net Diagrams	6-17
Area Communications System	2-2, 3-3	Multichannel Systems	6-18
Description	3-2	Preparing Procedures	6-19
Command System	3-4	Radio Net Diagram	6-20
COMSEC	5-19, 5-20, 5-21	Preparing Procedures	6-21
Conferencing	5-10	National Security Agency (NSA)	5-5
Contingency Planning	5-19	Nodes (Centers)	3-3
Corps Area Communications		Off-hook Service	5-10
Center (CASC)	3-5	Operational Resources Record	C-12
Corps Command		Performance Indicators	6-22
Communications System	3-4	Planning Elements	5-2
Corps Communication System	3-5	Preferential Services	5-10
Corps Level C-E Management	4-4	Radio Frequency Management	5-14

# Index (Cont)

---

<b>Item</b>	<b>Page</b>	<b>Item</b>	<b>Page</b>
Records .....	5-5	Telecommunications Service Order .....	C-20
Resources .....	5-8	Tempest .....	5-21
Assessment and Allocation .....	5-8	Terminology (General) .....	2-4
Definition .....	5-8	Testing (Circuits) .....	7-6
Responsibilities for .....	5-9	Theater Army .....	4-2
Restoration .....	7-5, B-9	Theater Army Frequency Management ...	5-15
Signal Estimate .....	5-1, 5-3	Theater Communication	
Preparation .....	5-3	Command (Army) (TCC(A)) .....	3-3, 4-3
Special Communication		Theater Frequency Management .....	5-15
Authorization Request .....	5-10, 5-11, C-18	Theater of Operations .....	3-2
Standard Operating Procedures (SOP) .....	5-4	Technical Parameters .....	2-3
System and Circuit Status Record .....	C-28	Traffic Control Measures .....	7-1
System Designation (Numbering) .....	B-3	Traffic Diagrams .....	6-11
System Designators (Numbers) .....	B-3	Traffic Route Bulletin .....	6-15
Systems Performance Analysis .....	6-23	Traffic Status Record .....	C-15
System Priority .....	B-9	Transmission System	
Tactical Automatic Switching (TAS) .....	7-5	Routing Control .....	7-2
Tactical Communication		TRI-TAC (Joint Tactical	
Control Facility (TCCF) .....	21-1, 2-3	Communication Program) .....	1-3
Tactical Telephone Numbering		User Locations .....	5-20
Plan (TTNP) .....	B-1	User Requirement .....	5-9
Technical Directives .....	5-11	U.S. Military C-E Board (MCEB) .....	5-17
Definition .....	5-11		
Levels for Issue .....	5-12		

# C-E Trouble Record

FOR USE OF THIS FORM, SEE FM 24-22  
PROponent AGENCY IS HQ, TRADOC

DTG

REPORT NUMBER

**1. STATION REPORTING**

**2. PERSON MAKING REPORT**

a. NAME \_\_\_\_\_

b. PROSIGN \_\_\_\_\_

c. POSITION \_\_\_\_\_

**3. RESTORATION PRIORITY**

**4. RE-ROUTE PATH**

**5. TROUBLE IDENTIFICATION**

a. SYSTEM NUMBER \_\_\_\_\_ TIME OUT \_\_\_\_\_ ETR \_\_\_\_\_

b. CIRCUIT NUMBER \_\_\_\_\_ TIME OUT \_\_\_\_\_ ETR \_\_\_\_\_

c. CIRCUIT GROUP NUMBER \_\_\_\_\_ TIME OUT \_\_\_\_\_ ETR \_\_\_\_\_

d. TERMINAL EQUIPMENT CODE \_\_\_\_\_ TIME OUT \_\_\_\_\_ ETR \_\_\_\_\_

**6. REASON FOR OUTAGE (RFO)**

a. INITIAL RFO \_\_\_\_\_

b. EXPLANATORY REMARKS:

**7. RESOURCES AFFECTED**

EQUIPMENT

a. NOMENCLATURE

b. UNIT

c. QUANTITY

d. RESOURCE CODE

PERSONNEL

e. GRADE/MOS

f. UNIT

g. QUANTITY

h. RESOURCE CODE

**8. REMEDIAL ACTION TAKEN OR ASSISTANCE REQUIRED**

**9. REMARKS**

**10. ACTUAL TIME OF RESTORATION**

a. INITIAL TROUBLE REPORT DTG \_\_\_\_\_ b. DTG OF RESTORATION \_\_\_\_\_

b. FINAL RFO \_\_\_\_\_ d. TIME REPORTED \_\_\_\_\_

**REASON FOR OUTAGE CODE**

Listed below are the most used codes. A more complete listing of RFO codes is found in DCAC 310-55-1, Volume II.

**First Character Location of Outage Code**

Code Letters	Meaning	Code Letters	Meaning	Code Letters	Meaning	Code Letters	Meaning
A	Distant End User Term	AC	Air Conditioning Equip	EU	RF Amplifier	NA	No Contact
B	TROPO Path Propagation	AP	Property Damage	EV	Telegraphic Multiplex	NB	No Trouble Found-CWT
C	Commercial Leased Facility	AQ	Enemy Action*	EW	VF Multiplex	NC	No Trouble Found-CBT
D	Distant End	AW	Weather*	EZ	Transmitter	NJ	Other*
E	Local CNCEIT)	BE	Operator Error*	FC	Frequency Change	NL	Unidentified*
F	Non-Mil US Sta FAC	BF	Quality Control Tr.-sting	GA	Tropo Scatter System	NP	Commercial Failure*
G	Nonreporting Mil Sta	BJ	Circuit Equalization	GB	VHF Radio System	NQ	User Wiring
H	Intersite Facility	BK	Station Movement	GC	Microwave Radio Sys	NR	User Equipment*
I	Interface US Mil System	BP	Preemption	GD	HF Radio System	NS	CNCEIT) Wiring
J	Intermediate CNCEIT)	BQ	Circuit Coordination	GE	UHF Radio System	NU	Coordination
K	Military Relay Site	BW	Control Seizure	GF	SHF Radio System	PA	Power Surge
L	Local Satellite Terminal	CN	Crypto Maint-Demand	JA	High Noise Level	PB	Power Dip
M	Distant End Sat Terminal	CP	Crypto Maint-Prevent	JB	High Signal Level	PC	Power Out-Contam Fuel
N	Unknown Location	CQ	Crypto Reset	JC	Low Signal Level	PE	Power Cable*
O	Airborne User Term (Radio)	EC	Error Detection	JD	Signal Loss	PF	Power Out-Mil Primary*
P	Path (Radio)	EE	Signaling Equipment	JE	Manmade Interference	PG	Power Out-Mil Pri & BU*
Q	Satellite	EF	Antenna	KF	Signal Distortion	PJ	Power Out-Cml Pri&BU*
R	Local Rev Site (Radio)	EH	Combiner	KG	Signal Fade	PK	Power Out-Cml&Mil*
S	Complete Local Sta Fac	EJ	Converter	KH	Frequency Shift Drift	PQ	AC Power Supply Equip
T	Local Xmr Site (Radio)	EL	Duplexer	KJ	Natural Interference	PR	DC Power Supply Equip
U	Local User Terminal	EM	Exciter	LK	Limited Bandwidth	OA	Submarine Cable*
V	Commercial-Foreign Sta FAC	EN	Heat Exchanger	LM	Reduced Channel OP	RA	Landline Cable 'Wire'
W	Path (Wire Cable)	EP	IF Amplifier	ME	Engineering*	SA	Satellite Degradation*
X	Interface Allied Mil Sta Fac	EQ	Modulator (MODEM)	MM	Modification*	SB	Satellite Failure
Y	Interface Allied Mil System	ER	Oscillator	MP	Preventive Maint	SC	Satellite Event*
Z	Unidentified (Initial Report Only)	ES	Power Amplifier	MQ	Installation	SD	Satellite Transmitter*
		ET	Receiver			SF	Satellite Receiver*
						SH	Satellite Tracking*

Asterisk Code (\*) must be explained in paragraph 6b

**Second and Third Characters Cause of Outage Code**

**RESOURCE STATUS CODE (RSC)**

First Character Condition	Second Character Cause	Third Character Operational Impact	First Character Condition	Second Character Cause	Third Character Operational Impact
1. Activation	1. Telecomm Svc Order	1. Increased Capability	5. Deactivation	5. Enemy Action*	5. Movement Required*
2. Reduced Operations*	2. Equipment Damaged	2. Reduced Cap Op*	6. Insufficient Equipment*	6. Personnel Casualty	6. Restoration Required
3. Inoperable Facilities	3. Equipment Failure	3. Personnel Required (MOS & NO)*	7. Improper Equipment	7. Weather	7. Frequencies Required
4. Insufficient Personnel	4. Equipment Destroyed *	4. Equipment Required (Type & No)*	8. Reduced Service	8. Personnel Error*	8. Frequencies Released
			9. Reserve Resources Used	9. Frequency Change*	9. Complete Loss of Service
			0 Other*	0 Other*	0 Other*

Asterisk Codes (\*) must be explained in paragraph 8

# Operational Resource Record

FOR USE OF THIS FORM, SEE FM 24 22  
PROONENT AGENCY IS HQ, TRADOC

DTG

REPORT NUMBER

<b>1. TO:</b>	<b>2. FROM:</b>
---------------	-----------------

<b>3. PRECEDENCE</b>	<b>4. SECURITY CLASSIFICATION</b>
----------------------	-----------------------------------

**5. TEAM STATUS**

a. TEAM CODE	b. NO. COMMITTED	c. NO. AVAILABLE	d. NO. INCOMPLETE

**6. CRITICAL SHORTAGES** *(Refers to incomplete teams and separate resources)*

**a. EQUIPMENT**

(1) TEAM CODE	(2) NOMENCLATURE	(3) QUANTITY	(4) REMEDIAL ACTION TAKEN

**b. PERSONNEL**

(1) TEAM CODE	(2) MOS TITLE	(3) GRADE	(4) QUANTITY	(5) MOS	(6) REMEDIAL ACTION TAKEN

<b>NAME &amp; TITLE OF PERSON REPORTING</b>	<b>SIGNATURE</b>
---	------------------



## Codes and Composition of Technical Teams

Team Type	Equipment Nomenclature	Team Code	No. of Per.	Major Signal Components	Vehicle	
AUTOMATIC SWITCH	AN TTC-25 (V1)	AS 251	7	AN TTC-25 (300)	2 1 2 T	
	AN TTC-25 (V2)	AS 252	7	AN TTC-25 (600)	2 1 2 T	
	AN TTC-38 (V1)	AS 381	7	AN TTC-38 (300)	2 1 2 T	
	AN TTC-38 (V2)	AS 382	7	AN TTC-38 (600)	2 1 2 T	
	AN TTC-41 (V1)	AS 383		SB-3614 TT	5 4 T	
	AN TTC-41 (V2)	AS 384		SB-3614 TT	5 4 T*	
CABLE CONSTRUCTION	AN TTC-41 (V3)	AS 385		SB-3614 TT	1 4 T R	
	Spiral 4	CC 027	12	3 Mi WF-8 G.(CX-11230 G)	3 4 T & 2 1/2 T	
	Field Wire	CC 017	8	6 Mi WD-1 TT, WF-16 U	3 4 T & 2 1/2 T	
MANUAL SWITCH	AN MTC-1	MS 001	3	AN MTC-1 (220)	2-2 1 2 T	
	AN MTC-7	MS 007	1	AN MTC-7 (60)	3 4 T	
	AN MTC-9	MS 009	9	AN MTC-9 (660)	2 Vans	
	AN TTC-35 (V1)	MS 351	1	AN TTC-35 (V1)(50)	1 1 4 T	
	AN TTC-35 (V2)	MS 352	2	AN TTC-35 (V2)(100)	1 1 4 T	
MULTIPLEXER	AN MCC-3	MU 003	3	1 AN TCC-8	3 4 T	
	AN MCC-6	MU 006	3	2 AN TCC-4, 1 AN TCC-7, 1 AN TCC-50	2 1 2 T	
	AN TCC-69	MU 060	3	2 TD-352	3 4 T	
	AN TCC-61	MU 061	3	8 TD-352	2 1 2 T	
	AN TCC-62	MU 062	3	2 TD-353	2 1 2 T	
	AN TCC-65	MU 065	3	4 TD-660	1 1 4 T	
	AN TCC-69	MU 069	3	2 TD-352	1 1 4 T	
	AN TCC-72	MU 072	3	2 TD-660	1 4 T	
	AN TCC-73	MU 073	3	2 TD-976, 8 TD-660	2 1 2 T	
	AN MRC-54	RR 054	3	3 AN TRC-24	2 1 2 T	
	AN MRC-103	RR 103	3	3 AN GRC-50	2 1 2 T	
	AN TRC-109	RR 109	3	2 AN GRC-50	3 4 T	
	AN TRC-110	RR 110	3	3 AN GRC-50	2 1 2 T	
	AN TRC-111	RR 111	3	1 AN GRC-147	2 1 2 T	
	AN TRC-113	RR 113	3	3 AN GRC-103	1 4 T	
AN TRC-138	RR 138	3	3 AN GRC-144	2 1 2 T		
AN TRC-152	RR 152	3	3 AN GRC-50	2 1 2 T		
RADIO TELETYPEWRITER	AN GRC-122	RA 122	4	AN GRC-122	3 4 T	
	AN GRC-142	RA 142	3	AN GRC-142	3 4 T	
	AN GRC-26D	RA 026	3	AN GRC-26D	2 1 2 T	
RADIO TERMINAL SET	AN MRC-68	RT 068	3	3 AN GRC-10, 2 AN TCC-3	3 4 T	
	AN MRC-69	RT 069	3	2 AN TRC-24, 1 AN TCC-7, 1 AN TCC-50	2 1 2 T	
	AN MRC-73	RT 073	3	1 AN TRC-24, 1 AN TCC-7, 1 AN TCC-20	2 1 2 T	
	AN MRC-102	RT 102	3	2 AN GRC-50, 1 AN TCC-7, 1 AN TCC-7, 1 AN TCC-20	2 1 2 T	
	AN TRC-108	RT 108	3	1 AN GRC-50, 1 TD-352	3 4 T	
	AN MRC-115	RT 115	3	2 AN GRC-103, 2 TD-660	1 1 4 T	
	AN TRC-117	RT 117	3	2 AN GRC-50, 2 TD-352	2 1 2 T	
	AN MRC-126	RT 126	3	1 AN GRC-103, 1 TD-660	1 1 4 T	
	AN MRC-127	RT 127	3	2 AN GRC-103, 2 TD-660	1 1 4 T	
	AN TRC-145	RT 145	3	2 AN GRC-103, 2 TD-660	1 1 4 T	
	AN TRC-151	RT 151	3	2 AN GRC-50, 2 TD-660, AN VRC-49, AN GSA-7	1 4 T	
	SIGNAL CENTER	AN MGC-9	SC 009	4	2 SB-86 TTY	2 1 2 T
		AN MGC-17	SC 017	4	2 TTY Terminals	3 4 T
		AN MGC-19	SC 019	8	10 TTY Terminals	2 1 2 T
		AN MGC-22	SC 022	8	8 TTY Terminals	5 T
AN MGC-23		SC 023	12	16 TTY Relay	5 T	
AN MSC-29		SC 029	10	12 TTY Terminals	2 1 2 T	
AN TSC-58		SC 058	10	12 TTY Terminals	2 1 2 T	
AN TSC-76		PP 076	3	1162 2 Wire Ckts	3 4 T	
CNCE	SB-611 MRC	PP 611	4	1162 2 Wire Ckts	3 4 T	
	SB-675 MSC	PP 675	4	954 2 Wire Ckts	2 1 2 T	
	AN TSQ-84	PP 084	3	972 4 Wire Ckts	2 1 2 T	
	AN TSQ-85	PP 085	4	4 TD-976	2 1 2 T	
	AN TRC-112	TS 112	3	1 AN GRC-143	2-1 1 4 T	
TROPO TERMINAL	AN TRC-121	TS 121	3	2 AN GRC-143	2-2 1 2 T	

Reverse of Operational Resources Report (Codes and Composition of Technical Teams)

# Traffic Status Record

FOR USE OF THIS FORM, SEE FM 24-22  
PROONENT AGENCY IS HQ, TRADOC

DTG:

1. TO:

2. FROM:

3. PRECEDENCE:

4. SECURITY CLASSIFICATION:

5. PERIOD OF REPORT:

FROM: (DTG)

TO: (DTG)

6. TOTAL TRAFFIC FOR PERIOD: *(Automatic Switch Data Only)*

	(1) ROUTINE	(2) PRIORITY	(3) IMMEDIATE	(4) FLASH	(5) FLASH OR
a. NARROWBAND-VOICE/SECURE					
b. NARROWBAND-TT-DATA/SECURE					
c. WIDEBAND					
	TOTAL			ATTEMPTS	COMPLETIONS
d. CALLS CLASSMARKED FOR MANUAL SERVICE	h. OPERATOR CALLS				
e. INTERCEPT CALLS	i. INFORMATION CALLS				
f. RECALLS	j. PROGRESSIVE CONFERENCE CALLS				
g. AVERAGE HOLDING TIME	k. PRE-PROGRAMMED CONFERENCE CALLS				

7. TOTAL CALLS BY TRUNK GROUP:

- AUTOMATIC SWITCH  
 MANUAL SWITCH (SELECTIVE PEG COUNTS)

a. TRK. GRP. NO.	b. INCOMING	c. OUTGOING PRIMARY ALTERNATE	d. PREEMPTION ATTEMPT COMPLETION	e. CALLS LOST PRIMARY ALTERNATE	f. MAINT.	g. LOCKOUT

8. TOTAL MESSAGE/CARDS BY TRUNK GROUP (RELAY)

a. TRUNK GROUP #	b. OUTGOING	c. INCOMING	d. BACKLOGGED

9. TOTAL MESSAGE/CARDS (TERMINAL)

FUNCTION	TYPE	1 ROUTINE	2 PRIORITY	3 IMMED	4 FLASH
a. TRANSMITTED	MSG/CARD	/	/	/	/
b. RECEIVED	MSG/CARD	/	/	/	/
c. BACKLOGGED	MSG/CARD	/	/	/	/
d. HANDLING TIME	MSG/CARD	/	/	/	/
e. UNACCOUNTED	MSG/CARD	/	/	/	/

10. MESSENGER SERVICE TOTALS:

- |   |                                       |
|---|---------------------------------------|
| a. SCHEDULED:<br>(1) AIR:<br>(2) MOTOR: | b. SPECIAL:<br>(1) AIR:<br>(2) MOTOR: |
|---|---------------------------------------|

# SPECIAL C-E AUTHORIZATION REQUEST

FOR USE OF THIS FORM. SEE FM 24 22  
PROponent AGENCY IS HQ. TRADOC

DTG:

1. TO:

2. FROM:

3. PRECEDENCE:

4. SECURITY CLASSIFICATION:

5. SUBSCRIBER INFORMATION: *(To Be Completed by Requester)*

a. ORGANIZATION:

b. LOCATION: *(Coordinates)*

c. DATE OF REQUEST:

d. DATE NEW SERVICE REQUIRED:

e. CURRENT COMMUNICATION SERVICE *(In Addition to Organic TOE)* PROVIDED:

(1) TRUNKS: VOICE \_\_\_\_\_ TELETYPEWRITER \_\_\_\_\_ DATA \_\_\_\_\_

(2) SUBSCRIBER: LOCAL LINES \_\_\_\_\_ EXTENSIONS \_\_\_\_\_

(3) PREFERENTIAL SERVICES: SPECIFY \_\_\_\_\_

(4) DEDICATED CIRCUITS: \_\_\_\_\_

(5) RWI CALL SIGN \_\_\_\_\_

(6) SPECIAL TERMINAL EQUIPMENT AUTHORIZED ABOVE DOCTRINE: \_\_\_\_\_

f. ADDITIONAL COMMUNICATION SERVICE REQUESTED:

g. JUSTIFICATION:

6. ASSESSMENT OF SCAR *(For Nodal Authority Use)*

a. ADDITIONAL RESOURCES OR FACILITIES REQUIRED:

b. AVAILABILITY OF REQUIRED RESOURCES/FACILITIES:

c. ADDITIONAL CONSIDERATIONS:

d. ACTION RECOMMENDED:

e. APPROVAL/DISAPPROVAL

SIGNATURE

# Telecommunications Service Order

FOR USE OF THIS FORM SEE FM 24-22  
PROONENT AGENCY IS HQ TRADOC

<b>1. TO:</b>	<b>2. FROM:</b>
---------------	-----------------

<b>3. INFO:</b>	<b>4. SECURITY CLASSIFICATION:</b>
	<b>5. PRECEDENCE:</b>

<b>6. TSO NUMBER:</b>	<b>DTG:</b>

**7. REFERENCE**

<b>a. HEADQUARTERS:</b>	<b>b. DTG:</b>	<b>c. SUBJECT:</b>

**8. SYSTEM/CIRCUIT INFORMATION:**

**a. ACTION REQUIRED:**  ACTIVATE  DEACTIVATE  REROUTE  MODIFY

**b. REQUIRED COMPLETION DTG:** \_\_\_\_\_ **c. RESTORATION PRIORITY:** \_\_\_\_\_

**d. STATION/FACILITY DESIGNATOR:** \_\_\_\_\_ **e. SYSTEM/CIRCUIT DESIGNATOR:** \_\_\_\_\_

**f. ROUTING INSTRUCTIONS:** \_\_\_\_\_ **g. USER IDENTIFICATION:** \_\_\_\_\_

**h. INTERFACE:** \_\_\_\_\_ **i. CONDITIONING:** \_\_\_\_\_

**j. WIRE/CABLE (1) TYPE:** \_\_\_\_\_ **(2) TERM A LOC:** \_\_\_\_\_ **(3) TERM B LOC:** \_\_\_\_\_

**k. RADIO SYSTEMS:**

**(1) TERM A LOC:** \_\_\_\_\_

**(a) ANTENNA:** AZ \_\_\_\_\_ HT \_\_\_\_\_ PLRZ \_\_\_\_\_ **(b) FREQUENCY:** S \_\_\_\_\_ R \_\_\_\_\_ **(c) CALL SIGN:** \_\_\_\_\_

**(2) TERM B LOC:** \_\_\_\_\_

**(a) ANTENNA:** AZ \_\_\_\_\_ HT \_\_\_\_\_ PLRZ \_\_\_\_\_ **(b) FREQUENCY:** S \_\_\_\_\_ R \_\_\_\_\_ **(c) CALL SIGN:** \_\_\_\_\_

**(3) RELAY \_\_\_\_\_ LOC \_\_\_\_\_ CALL SIGN \_\_\_\_\_**

**(a) ANT AZ \_\_\_\_\_ HT \_\_\_\_\_ PLRZ \_\_\_\_\_ FREQ S \_\_\_\_\_ R \_\_\_\_\_**

**(b) ANT AZ \_\_\_\_\_ HT \_\_\_\_\_ PLRZ \_\_\_\_\_ FREQ S \_\_\_\_\_ R \_\_\_\_\_**

**9. EQUIPMENT INFORMATION:**

**a. ACTION REQUIRED:**  INSTALL  REMOVE  MODIFY  REPAIR/REPLACE

OTHER \_\_\_\_\_

<b>b. TYPE/MODEL NUMBER</b>	<b>c. QUANTITY</b>	<b>d. LOCATION</b>

**10. REMARKS:** *(Use back of form if necessary)*

<b>DTG COMPLETED AND REPORTED</b>	<b>PERSON VERIFYING COMPLETION</b>

# C-E System Document Change Order

FOR USE OF THIS FORM, SEE FM 24-22  
PROPOSER AGENCY IS HQ, TRADOC

DTG:

1. TO:

FROM:

3. INFO:

4. SECURITY CLASSIFICATION:

5. PRECEDENCE:

6. CHANGE ORDER NUMBER:

7. EFFECTIVE DTG OF CHANGE:

8. REFERENCE DOCUMENT:

a. TITLE

b. NUMBER

c. DTG

9. NARRATIVE DESCRIPTION OF CHANGE:

a. DELETION:

b. ADDITION:

AUTHORIZED BY: NAME, TITLE

SIGNATURE

### SYSTEM AND CIRCUIT STATUS RECORD

1. SYSTEM/CIRCUIT NO.		2. TERMINAL - TO		FROM		3. TYPE	4. CONTROL CSCE		5. RP
6. TSO/AUTHORITY NO.		DTG		7. DTG ACTIVATED			8. USER - TITLE		
9. SYSTEM TERMINAL EQUIPMENT			10. CIRCUIT TERMINAL EQUIPMENT			11. USER-CONTACT TEL. NO.			
12. SYSTEM INTERFACE EQUIPMENT			13. CIRCUIT INTERFACE EQUIPMENT			14. CIRCUIT CONDITIONING EQUIPMENT			
ANALOG/DIGITAL CONVERTER		DC TELEGRAPH LINE CONVERTOR		AMPLITUDE EQUALIZER					
ASYNCHRONOUS DIG COMBINER		IMPEDENCE MATCHING		ATTENUATOR					
CRYPTOGRAPHIC UNIT		MODEM RATE: _____		DELAY EQUALIZER					
DATA BUFFER		SIGNALLING CONVERTER		ECHO SUPPRESSOR					
DIGITAL MULTIPLEXER		OTHER:		LINE AMPLIFIER					
VF MULTIPLEXER				PAD					
OTHER:				REGENERATIVE REPEATER					
				RELAY COIL					
				OTHER:					
15. ROUTING									
16. SYSTEM TERMINATION IDENTIFICATION						SYSTEM NO. _____		17. CIRCUIT PANEL APPEARANCE	
GROUP	DESIGNATOR	CH	GROUP	DESIGNATOR	CH	IN	OUT		
1			5						
2			6						
3			7						
4			8						
1. SYSTEM/CIRCUIT NO.		2. TERMINAL - FROM		TO		3. TYPE	4. CONTROL CSCE		5. RP

DA Form 4623-R  
1 JUN 77

FOR USE OF THIS FORM, SEE FM 24-22  
PROONENT AGENCY IS HQ, TRADOC

18. TROUBLE AND RESTORATION RECORD						
a. DTG OUT	b. DTG IN	c. RFO (CODE)	d. ACTION TAKEN			
19. SYSTEM/CIRCUIT MODIFICATIONS						20. REMARKS:
CHANGE	AUTHORITY	DTG	CHANGE	AUTHORITY	DTG	
1			6			
2			7			
3			8			
4			9			
5			10			

1 SYSTEM NO		2 TERMINAL FROM TO		3 TYPE		4 CONTROLLING CSCE		5 RP		6 GROUP	
GROUP	CHAN	CIRCUIT NUMBER		RP	GROUP	CHAN	CIRCUIT NUMBER		RP		
	1					1					
	2					2					
	3					3					
	4					4					
	5					5					
	6					6					
	7					7					
	8					8					
	9					9					
	10					10					
	11					11					
	12					12					

**SYSTEM AND CIRCUIT STATUS RECORD -  
SYSTEM CHANNEL ALLOCATION**

<b>SYSTEM AND CIRCUIT STATUS RECORD - SYSTEM CHANNEL ALLOCATION</b>											
GROUP	CHAN	CIRCUIT NUMBER		RP	GROUP	CHAN	CIRCUIT NUMBER		RP		
	1					1					
	2					2					
	3					3					
	4					4					
	5					5					
	6					6					
	7					7					
	8					8					
	9					9					
	10					10					
	11					11					
	12					12					

1 SYSTEM NO		2 TERMINAL FROM TO		3 TYPE		4 CONTROLLING CSCE		5 RP		6 GROUP	
-------------	--	--------------------	--	--------	--	--------------------	--	------	--	---------	--

**30 JUNE 1977**

By Order of the Secretary of the Army:

**BERNARD W. ROGERS**  
*General United States Army*  
*Chief of Staff*

Official:

**PAUL T. SMITH**  
*Major General, United States Army*  
*The Adjutant General*

**DISTRIBUTION:**

*Active Army, USAR, and ARNG:* To be distributed in accordance with DA Form 12-11 A, Requirements for Tactical Communications Doctrine; and Field Radio Techniques (Qty rqr block no. 211 and 215).

Additional copies can be requisitioned (DA Form 17) from the US Army Adjutant General Publications Center, 2800 Eastern Boulevard, Baltimore, MD 21220.



**PIN: 033195-000**